



GZ Zero Clearance Van-Packer Pre-Fab Ductwork with Spring Air Systems Hoods for Commercial Kitchens Engineering and Installation Manual

Spring Air Systems Inc., Oakville, Ontario
Phone (905) 338-2999, Fax (905) 338-0179, info@springairsystems.com
www.springairsystems.com

**GZ Zero Clearance Van-Packer Pre-Fab Commercial Kitchen
Duct Engineering and Installation Manual with
Spring Air Systems Kitchen Hoods
Table of Contents**

Description	Page
INTRODUCTION	1
IT'S ALL IN THE CONNECTION: - JOINT ASSEMBLY	3
CLEARANCES	4
SPECIAL CONSIDERATIONS	4
DUCT SIZE & SLOPE	4
THERMAL EXPANSION	5
CLEANOUTS	5
GREASE TRAPS	6
ROOF TERMINATIONS	7
FN HOOD EXHAUST DUCT COLLAR TERMINATION	10
HOOD FN EXHAUST DUCT COLLAR TERMINATIONS WITH ZONEFLOW AND J-COUPLE	11
HOOD FD EXHAUST FIRE DAMPER DUCT COLLAR TERMINATION	13
HOOD FD EXHAUST FIRE DAMPER DUCT COLLAR TERMINATION WITH ZONEFLOW AND J-COUPLE	14
CLEANING & FIRE SUPPRESSION	15
ONE HOOD ONE FAN WITH REQUIRED OFFSETS	16
TWO HOODS ONE FAN WITH REQUIRED OFFSETS	18
THREE HOODS ONE FAN WITH REQUIRED OFFSETS	20
TYPICAL DUCTWORK RUN SHOWING COMPONENTS	22
PART IDENTIFICATION	23
EXHAUST DUCT DIAMETER VAN PACKER CONNECTED TO SPRING AIR HOODS	28
MAXIMUM DUCT DIAMETER – FOR SERIES XF-B SPUN ALUMINUM EXHAUST FANS	31
SUPPORTING THE PRE-ENGINEERED DUCTWORK DESCRIPTION	32
SQS ONLINE GZ DUCT PROGRAM MODULE	38

All of the Van Packer GZ components are not shown in this manual. Refer to the Van Packer GZ Installation Instructions for the complete list of components.

VAN-PACKER GZ PRE-ENGINEERED COMMERCIAL KITCHEN DUCT WITH SPRING AIR SYSTEMS KITCHEN COMPONENTS

GZ Zero Clearance Van-Packer Pre-Fab Duct Engineering and Installation Manual

INTRODUCTION

The SPRING AIR SYSTEMS INC. /Van Packer Co Inc. zero clearance pre-fabricated duct work has been designed and constructed specifically for a commercial kitchen exhaust systems. The components are easy to install to provide a complete zero clearance duct run from the hood to the fan.



*Figure 1
Spring Air FN-B-MB with Van Packer Pre-Engineered Ductwork*

The GZ Zero Clearance Pre-fabricated duct is built-in accordance to the National Building Code, National Fire Protection Association (NFPA-96) and listed to Underwriters Laboratories of Canada and Underwriters Laboratories Inc. standards. Tested to UL 1978/ULC S662, UL 2221/ULC S144, ASTM E814.

NOTE: PRIOR TO ANY GZ ZERO CLEARANCE PRE-FABRICATED DUCT INSTALLATION THE INSTALLER MUST SEEK THE APPROVAL OF THE AUTHORITY HAVING JURISDICTION.

GZ ZERO CLEARANCE PRE-FABRICATED DUCTWORK:

The Van Packer Co Inc. GZ duct provides a manageable alternative to the most difficult commercial kitchen exhaust installation situations.

Here's a few;

- Eliminates any restriction in historical buildings of wood or partial wood construction.
- Lower cost alternative to "old school" fabricated 16ga metal duct welded on site.
- Substantially faster installation because there is no welding.
- Safer installation because there is no welding.
- Eliminates the use of special clearance reduction products such as wraps or boards.
- Confident that once assembled the Pre-Fabricated Zero Clearance ductwork will pass any further smoke tests by local municipalities.
- A Pre-Engineered product listed to ensure repeatability installation after installation.
- A dedicated duct shaft is not required saving installation cost.
- Stainless steel or brushed Aluminum finish providing attractive installation
- Less static than rectangular duct requiring less motor HP and energy savings.

IT'S ALL IN THE CONNECTION: - JOINT ASSEMBLY

This is how Van Packer makes the grease duct liquid tight without welding. The following tools are recommended: Philips screwdriver, vice grip pliers (D-shape), hammer/mallet, and a caulking gun (manual, power, or pneumatic screwdrivers and caulking guns are acceptable). *No welding machine.*

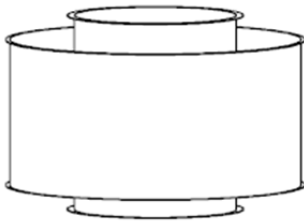

Figure 2
STR straight

This is a STR – straight section. It consists of the inner stainless steel duct with a rolled edge top and bottom, aluminum or stainless steel outer casing with insulation between the two.

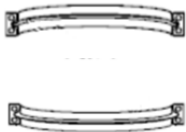

Figure 3
VEE Bands

These are the VEE-BANDS. The two half are wrapped around the bottom and top rolled edges of the STR pieces and bolted together. Nuts and bolts supplied by Spring Air. Prior to wrapping the VEE-BANDS around the rolled edges Use high temperature silicone sealant, Van-Packer part number 101087A is applied to one of the rolled edges and inside of the two VEE-BANDS. The high temperature silicone sealant is supplied with the job by Van Packer.

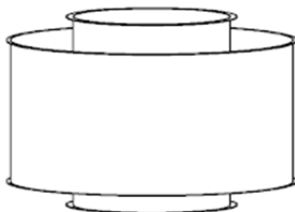

Figure 4
STR straight

This is the lower STR –straight section. The STR sections come in 18" (457mm), 30" (762mm), and 42" (1067mm), to install horizontally or vertically.

NOTE: NORMALLY THE INSULATION AND DRAW BANDS ARE NOT INSTALLED UNTIL AFTER ALL OF THE DUCT INCLUDING VEE BANDS ARE COMPLETED AND NO FURTHER ADJUSTMENTS ARE REQUIRED.

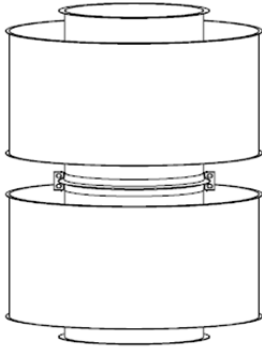

Figure 5
2 x STR straight connected with
VEE-Bands

Butt the rolled edges together of the two STR pieces being joined and then rotate slightly to ensure sealant coverage. Place the VEE-BAND halves around the STRs rolled edges. With the provided fasteners draw the VEE-BAND halves together. Remove/wipe/smooth any excess sealant on the inside of the assembled duct. Here are the two STR sections attached together using the two VEE-BANDS. The two bolts on each end of the VEE-BAND are tighten

Now fill the gap between the two connected STR sections with the insulation strip provided. Wrap the assembled VEE BAND joint three times completely with a 2" overlap at the end of the last wrap. If more than one strip is required, overlap 2" before beginning to wrap with the additional strip(s). Wrap the joint tight enough for the insulation to fit in the space between the liner & shell.

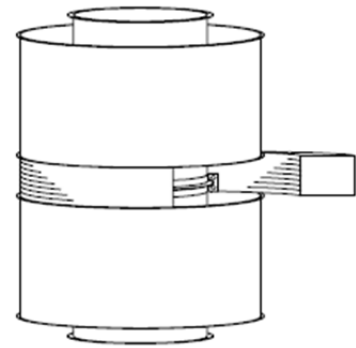
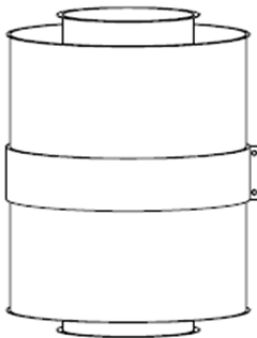

Figure 6
2 x STR straight connected with V-Bands



2 x STR straight connected with
Draw-Bands

Place the DRAW BAND around and overlapping the STR flanges with the provided fasteners and using the appropriate tools draw up the band tight. More detailed instructions can be found at the end of engineering section in the installation section of this manual. This same procedure is used to connecting to hoods, fans, elbows, tees, wyes etc.

For outdoor applications and food proceeding facilities apply the sealant to the draw band edges.

WHAT IS REQUIRED TO DESIGN A VAN PACKER EXHAUST DUCT VENTILATION SYSTEM?

1. Ductwork offset from exhaust fan curb center point to each hood duct collar center-point connected to the exhaust fan.
2. Height from top of finished floor to the top of the roof deck.
3. Type of exhaust fan; vent set or spun aluminum.
4. Vertical obstructions that would cause the path of the duct to change.
5. Horizontal obstructions that would cause the path of the duct to change.
6. Multiple storey duct runs require location of the proposed duct cut-outs through each floor.
7. Exhaust air volume for each hood.
8. Exhaust air volume for each exhaust fan.

CLEARANCES:

The clearance to non-combustible materials is zero inches. Where a component or assembled components are insulated and enclosed by their respective shell, cover, or draw band for all installations except within a completely enclosed non-ventilated combustible enclosure the clearance to combustible materials is zero inches. For installations within a completely enclosed non-ventilated combustible enclosure (UL 2221/ULC S144 condition B), the required minimum clearance to the duct shell is ¼" (combustible materials may be at zero clearance to draw bands and covers only for this installation condition).

SPECIAL CONSIDERATIONS:

Typically, Van-Packer grease duct components are intended to comprise the complete system. However, we realize conditions occur where a portion of an existing grease duct system may need to be replaced or due to space constraints a system may need rectangular portions. In these cases, it is permissible to transition to/from a code compliant grease duct system by others to/from Van-Packer grease duct components when; final connections to the Van-Packer duct are in accordance with an approved joint assembly method as described within applicable installation instructions, the transition piece is connected to duct by others in accordance with applicable codes and construction methods, and the transition/duct by others maintains the proper airspace clearances or is protected with a fire rated enclosure as described by applicable codes. **WARNING:** Listings/warranties may be affected when transitioning grease ducts by others; consult Van-Packer technical service department for additional information.

Code compliant clearances must be observed for a component or assembled components which are not insulated and enclosed by a shell, cover, or draw band. Code compliant clearances must also be observed where components or portions of components are in direct contact with the liner (I.D.) and protrude past the duct shell, cover, or draw band; e.g., plate support assemblies, drain nipples, etc. When installed in accordance with these instructions and applicable codes, Model GZ grease ducts are equivalent to field fabricated two hour fire rated grease duct enclosure systems. Do not apply wraps or enclosure materials in direct contact with Model GZ components in a manner as to have the Model GZ duct act as the supporting member or structure for the supplemental wrap or enclosure. Model GZ has not been tested, listed, designed, etc. to carry extra weight.

DUCT SIZE & SLOPE:

The GZ duct connected to the hood will be determined by the diameter of the hood duct collar. Hood duct collar diameter sizes are normally between 1500 and 1600 fpm. Larger main GZ ducts will be sized for 1800 fpm for runs to the exhaust fan. GZ duct results in lower static pressure than rectangular field fabricated and installed ductwork. Model GZ grease ducts must be installed accordingly to comply with the requirements as described by the cULus listing in order to maintain a listed installation. The UL 2221/ULC S144 standard (Tests of Fire Resistive Grease Duct Enclosure Assemblies) states that these grease ducts must comply with requirements as set forth by UL 1978/ULC S662 (Grease Ducts), NFPA 96 (Standard for Ventilation Control and Fire Protection of Commercial Cooking Operations), and the International Mechanical Code. Van Packer is listed for reduced slope installations.

LISTED FOR REDUCED SLOPE REQUIREMENTS



Figure 8
Horizontal GZ duct breaching

- drain is installed at the 75' mark.
3. Ducts greater than 75' in length which are not going to be "peak – valley" pitched or have intermittent drains must then be pitched at 3/16" per foot (for metric it can be worded 3/16 unit vertical for 12 units horizontal).

1. Ducts less than 75' in length = 1/16" per foot (for metric it can be worded as 1/16 unit vertical for 12 units horizontal)
2. To keep the 1/16" slope for ducts greater than 75' in length:
 - a. After the first 75' pitched up (peak point) – then pitch the duct down at 1/16" per foot for a maximum distance of 75' (valley point). Must have a drainage point in the valley. Systems can continue in this manner – pitch up, pitch down to drain or hood, pitch up. Please also note this method allows for a maximum of 150' of duct between a hood and a riser to a fan, so long as the riser base is equipped with a drain.
 - b. You may continue at a slope of 1/16" per foot after the initial 75' if a

Most Model GZ components will permit a small amount of slope as the system is being installed. However, some installations may require elbow/transition type pieces to allow for proper orientation of fittings at the vertical risers prior to and after long horizontal runs.

THERMAL EXPANSION:

Model GZ grease duct lengths between two fixed points which are subject to more than ¼" expansion must have an adjustable expansion section (part ADJ). The assembled length of grease duct components between two fixed points must also have adequate intermittent guide type braces (e.g. full angle rings part FAR) to prevent the binding or excessive bending of the assembled duct. The system designer must be aware that the inner joints have negligible flexing capability and that tee sections, elbows, etc. have not been designed to withstand excessive bending forces. The liners and shells are held together with clips; and while the liners and shells will move at slightly different rates, the shells will still move. Guides and breaching supports must be placed far enough away from draw bands, adjustable expansion joint covers, etc. in order to prevent binding or excessive bending of the assembled duct.

The total linear expansion between two fixed points can be calculated according to the following:

$$LE = \text{Length} \times SLE \times ET$$

Where:

LE: = Linear Expansion: (inches)

Length: =Length Between two Fixed Points (inches)

SLE: =Stainless Linear Expansion Coefficient: (0.0000089 inch/inch/°F)

ET: =Exhaust Temperature. (Degrees °F) Use 500F.

When LE (Linear Expansion) is greater than ¼" an expansion joint is required

CLEAN-OUTS:

Grease ducts must be provided with adequate cleanout doors or openings to allow for the inspection and cleaning of the entire grease duct system. Where horizontal or vertical ducts are not large enough for a person to enter the ductwork or the duct is large enough but a person will not enter the duct to clean then the following applies:

1. Grease ducts are to be provided with cleanouts at changes in direction.
2. Located clean-outs at the top of vertical risers.
3. Clean-out are required from kitchen hoods with vertical riser higher than 16'0"
4. When grease ducts are not 20" x 20" (508mmx508mm) minimum then the cleanouts must be located at 12' (3657mm) intervals in horizontal ducts.
5. Cleanout required on every floor for vertical ducts.
6. A 90 degree elbow from a vertical riser to a horizontal can be substitute for a WYE Tee. The WYE tee when line of site is possible from the cleanout-out down the vertical and horizontal duct.
7. Part FAR, full angle rings are recommended at each Clean-out.



Figure 9
Cleanout on Horizontal GZ duct

Refer to NFPA 96 for requirements accordingly. Cleanout openings in horizontal ducts must be located at the sides or at the top of the duct. Many Model GZ sections, accessories, and combinations can be used for cleanout and inspection access of the grease duct system. Access panel sections, 90° tee sections with end caps, and many other combinations of components can serve as cleanout doors or openings as described by NFPA 96.

WARNING: Cleanout doors or openings must be completely comprised of Model GZ grease duct components. Do not field install clean out doors or openings by means of drilling, cutting, puncturing, etc. through the outer shell/cover or into the liner of any Model GZ component. Such modifications will void the grease duct listing, warranty, and may cause failure of the grease duct system with respect to its fire containment and liquid tight integrity.

GREASE TRAPS:

Cleanouts should be located near drain sections with internal dams to allow for the inspection and cleaning of the dam area and initial drain pipe piece as it leaves the grease duct. It is recommended that all drains for a manually cleaned grease duct be fitted with a grease trap to allow for grease, which flows into a drain as part of normal operation, to be contained outside of the duct.

Grease traps should be mounted as close as possible to drains in an attempt to have the grease flow into the trap while it is still warm rather than cooling and solidifying in a long pipe length (causing an obstruction) prior to the trap. Remove grease traps prior to cleaning the grease duct system. Van-Packer does not provide or size grease traps. Please refer to NFPA 96 as required. Cleanout, drain, and grease

trap requirements may change when grease duct systems are equipped with automatic cleaning and/or some types of fire suppression equipment. Refer to NFPA 96 and consult with authorities having jurisdiction for specific duct system requirements.

An offset GZ duct assembly with 30 to 45 degree elbows is shown to the below in figure 10. A clean-out was not required in the vertical riser because of the spun aluminum fan mounted on the roof above.



Figure 10
Offset using 30 degree elbows with
no Cleanout

**ROOF TERMINATIONS:
SPUN ALUMINUM ROOF CURB ASSEMBLY:**

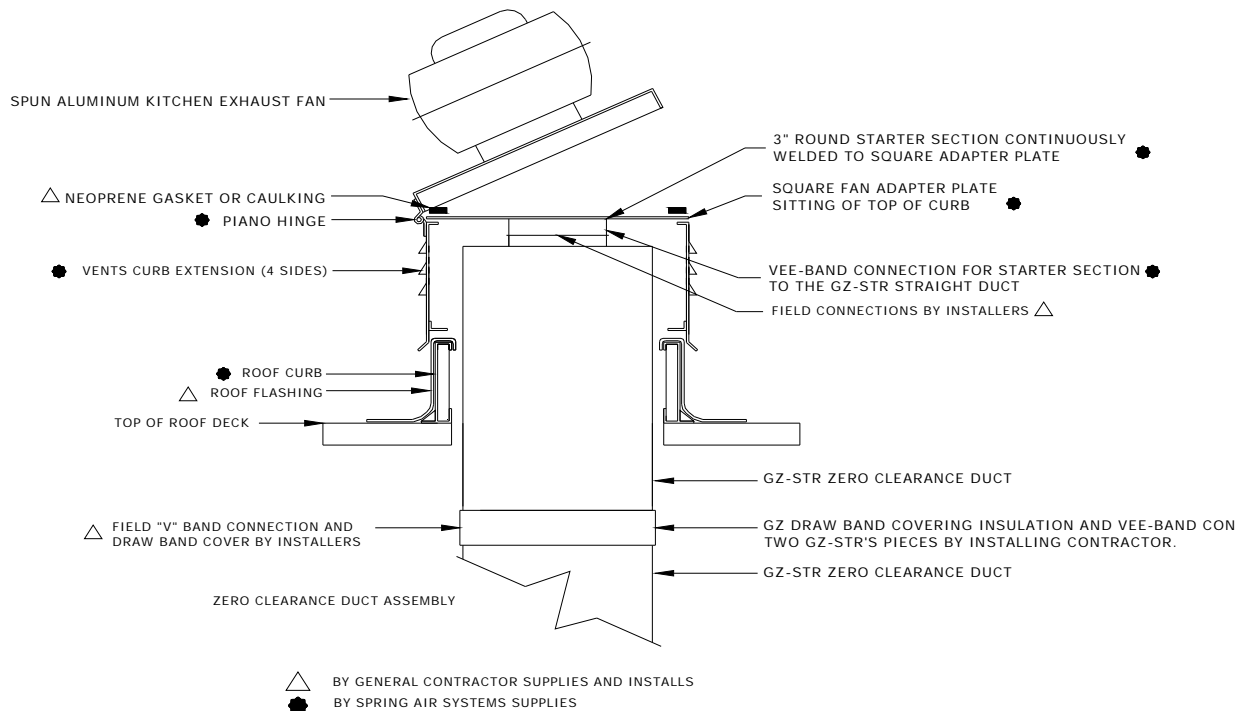
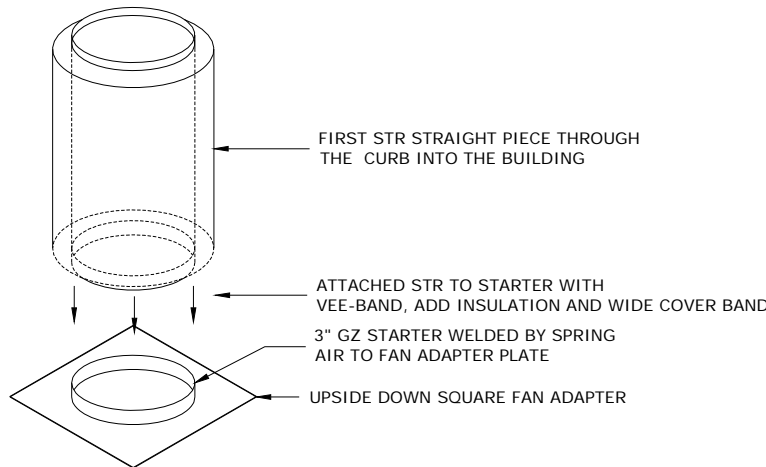

Figure 13
Top of Spun-Aluminum Fan Curb Assembly.

When Spring Air Systems provides the exhaust fan and curb assembly the Roof Curb is shipped to site first to be installed by the roofer.

The installation of the GZ ductwork starts at the top of the exhaust fan curb. The Ventilated Curb is set on top of the Roof Curb. A Square Fan Adapter Plate matching the top of the Ventilated Curb is supplied with a 3" GZ starter piece welded to the center hole in the Square Fan Adapter Plate.

To start the installation turn the Square Fan Adapter piece over so the 3" GZ starter's rolled flange is pointing up.



Make the V band connection per the joint assembly instructions and then wrap the joint with provided insulation and enclose the insulation in a wide cover band.

Now turn the assembly upside two and insert into the top of the Ventilated Curb to allow the STR straight section to stick out below the curb under the roof deck inside the building.

Figure 12
Attaching Starter to STR Straight



Now the rest of the GZ duct work is completed starting from this STR and working back towards the hood duct collar.

An alternative is to use an Adjustable Section through the curb. Connect the piece to the fan adapter and drop through the roof. Measure the distance required and them pull the adjustable out of the fan curb and adjust the length to suite.

Figure 11
Spun Aluminum fan curb connection with GZ duct

FOR ALTERNATIVE INSTALLATION METHODS CONTACT THE FACTORY

The picture above shows the top of the Fan Adapter plate sitting on the Ventilated Curb. The continuously welded GZ Starter can be seen extending into the Ventilated Roof curb showing the joint where the first STR straight has been connected. The exhaust fan is hinged to the curb on the top left side of the picture. Two cables support the fan when it is hinged open for inspection and cleaning of the ductwork.

VENT SET ROOF TOP GZ DUCT ASSEMBLY:

When Spring Air Systems provides the Vent Set exhaust fan and roof opening the Roof Opening is shipped to site first. The Roof Opening is installed by a Roofing Contractor.

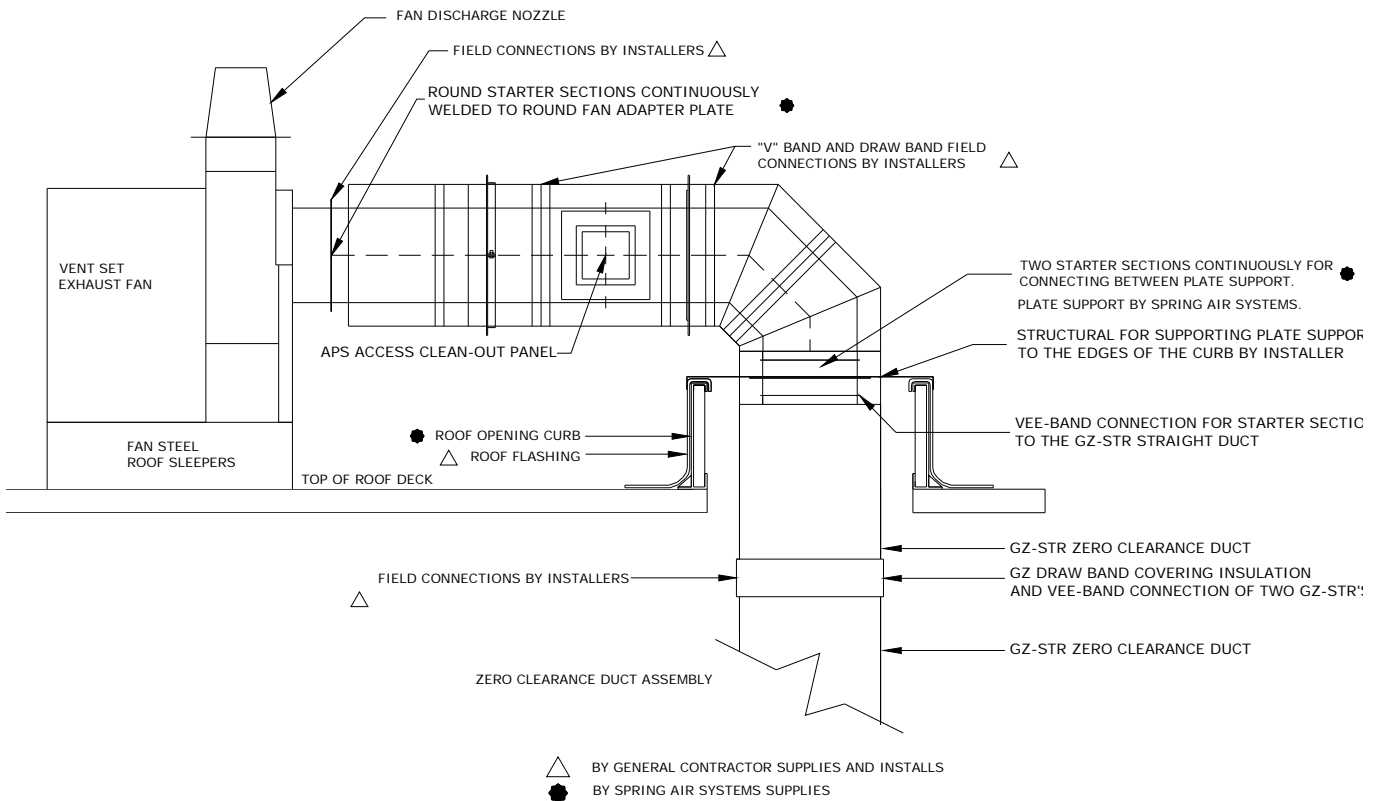

Figure 14
Vent Set Exhaust fan connected to GZ duct

Make the V band connection per the joint assembly instructions and then wrap the joint with provided insulation and enclose the insulation in a wide cover band. Starter pieces are used to make it easier to install the Plate Support between the two duct pieces. Using structural pieces connect the Plate Support to the top of the Roof Opening curb. After the STR Straight sections are connected to the starter pieces turn the assembly upside down and insert into the top of the roof opening Curb to allow the STR straight section to stick out below the curb under the roof deck inside the building.

Next assembly the GZ ductwork starting from the exhaust Vent Set round exhaust inlet GZ starter to the GZ starter on the top of the Square Roof Opening Curb Adapter. This will include a horizontal Cleanout and elbow.

FOR ALTERNATIVE INSTALLATION METHODS CONTACT THE FACTORY

FN HOOD EXHAUST DUCT COLLAR TERMINATION

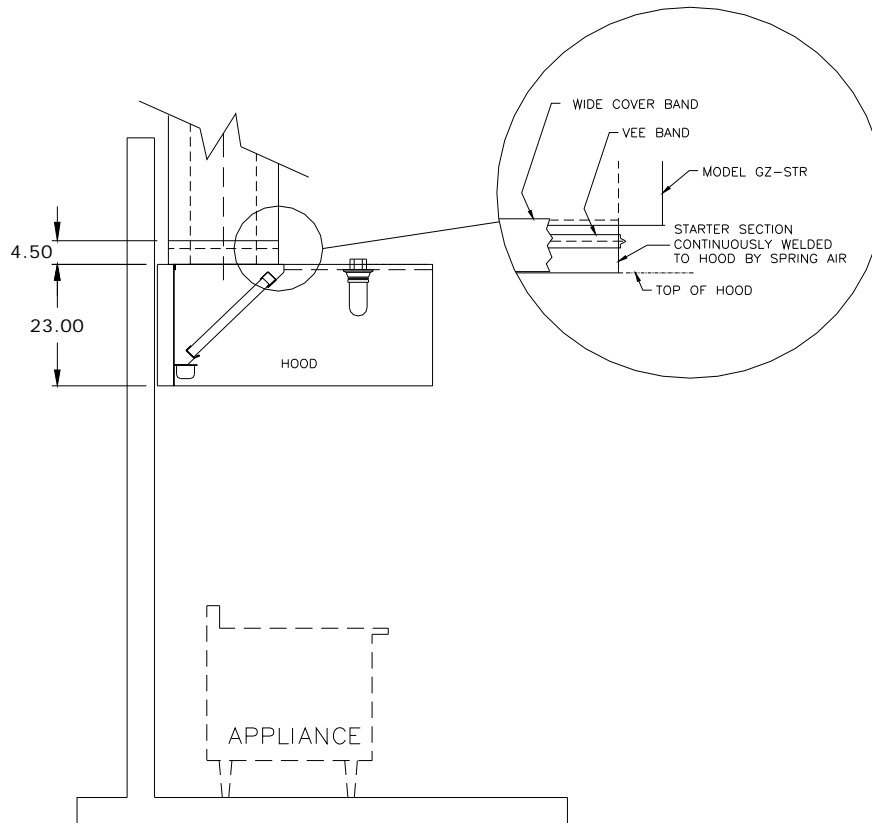

Figure 15
Spring Air FN Hood connection to duct



Figure 16
Looking inside a hood at welded starter section

The Spring Air Systems FN hood duct collar has a round starter section welded to the top of the hood by the factory. Make the V band connection per the joint assembly instructions and then wrap the joint with provided insulation and enclose the insulation in a wide cover band. This same procedure is used to connecting to hoods, fans, elbows, tees, WYE's etc.

HOOD FN EXHAUST DUCT COLLAR TERMINATION WITH ZONEFLOW AND J-COUPLE

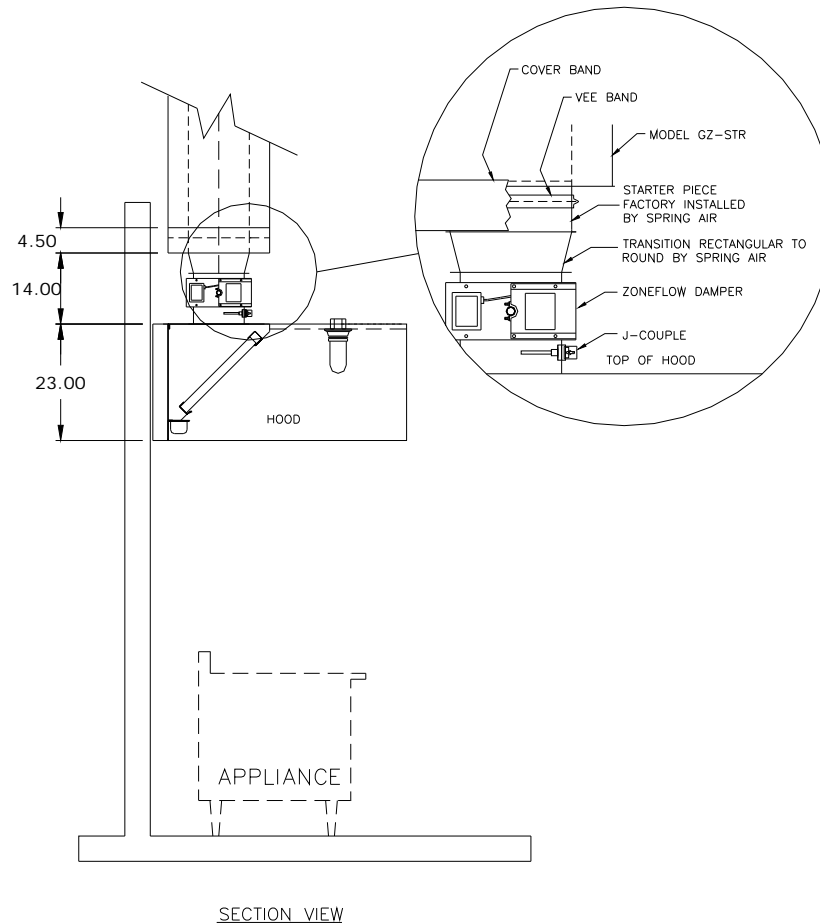

Figure 16
Spring Air FN Hood, with Zoneflow and J-Couple and Starter

The Spring Air Systems FN hood duct collar has a round starter piece welded to the top of the Zoneflow Damper by the factory. Make the V band connection per the joint assembly instructions and then wrap the joint with provided insulation and enclose the insulation in a wide cover band. Should the authority having jurisdiction require insulation on the Truflow damper use the Van Packer insulation and wide cover band wrapped as before and overlapping the top outside shell by 3" (76mm).

WARNING

Code compliant clearances must be observed for a component or assembled components which are not insulated and enclosed by a shell, cover, or draw band. Code compliant clearances must also be observed where components or portions of components are in direct contact with the liner (I.D.) and protrude past the duct shell, cover, or draw band. When installed in accordance with these instructions and applicable codes, Model GZ grease ducts are equivalent to field fabricated two hour fire rated grease duct enclosure systems. Do not apply wraps or enclosure materials in direct contact with Model GZ components in a manner as to have the Model GZ duct act as the supporting member or structure for the supplemental wrap or enclosure. Model GZ has not been tested, listed, designed, etc. to carry extra weight.



Figure 17
Spring Air FN Hood, with Zoneflow and J-Couple and Starter Piece



Figure 18
Closer View of Zoneflow and J-Couple with Starter piece

HOOD FD EXHAUST FIRE DAMPER DUCT COLLAR TERMINATION

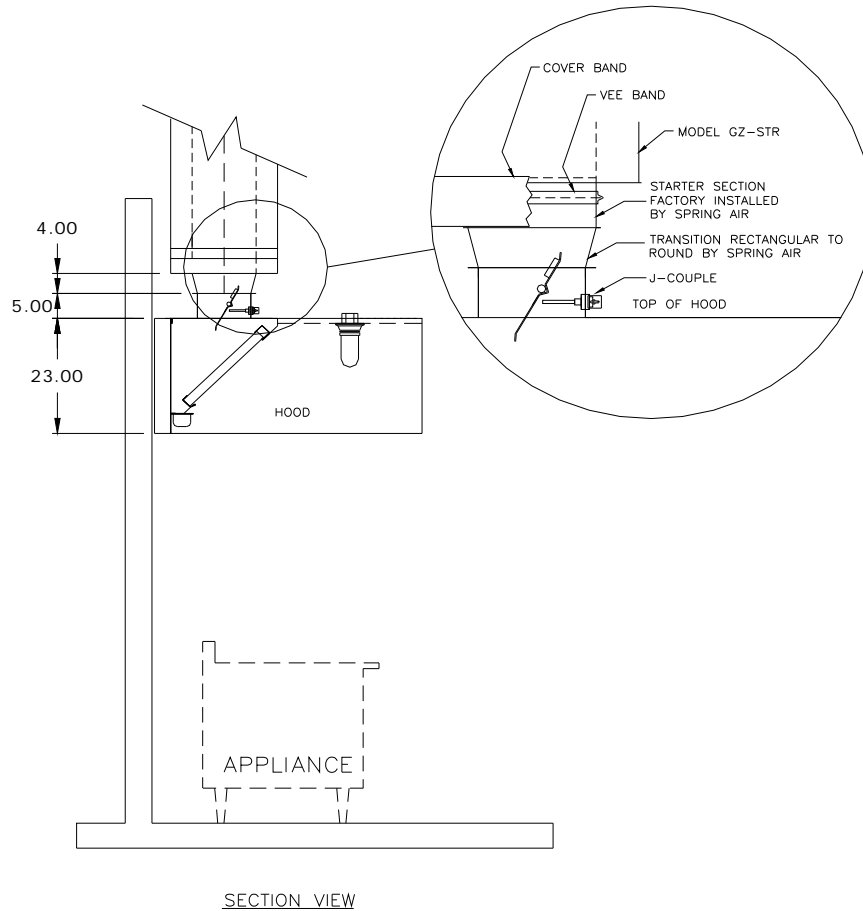

Figure 19
Spring Air FD Hood with GZ Starter Piece

The Spring Air Systems FD hood duct collar has a round starter section welded to the top of the Exhaust Fire Damper by the factory. Make the V band connection per the joint assembly instructions and then wrap the joint with provided insulation and enclose the insulation in a wide cover band. The authority having jurisdiction may require insulation and wide cover band wrapped around the Exhaust Fire Damper from the top starter piece to the roof of the hood.

NOTE: NORMALLY THE INSULATION AND DRAW BANDS ARE NOT INSTALLED UNTIL AFTER ALL OF THE DUCT INCLUDING VEE BANDS ARE COMPLETED AND NO FURTHER ADJUSTMENTS ARE REQUIRED.

HOOD FD EXHAUST FIRE DAMPER DUCT COLLAR TERMINATION WITH ZONEFLOW AND J-COUPLE

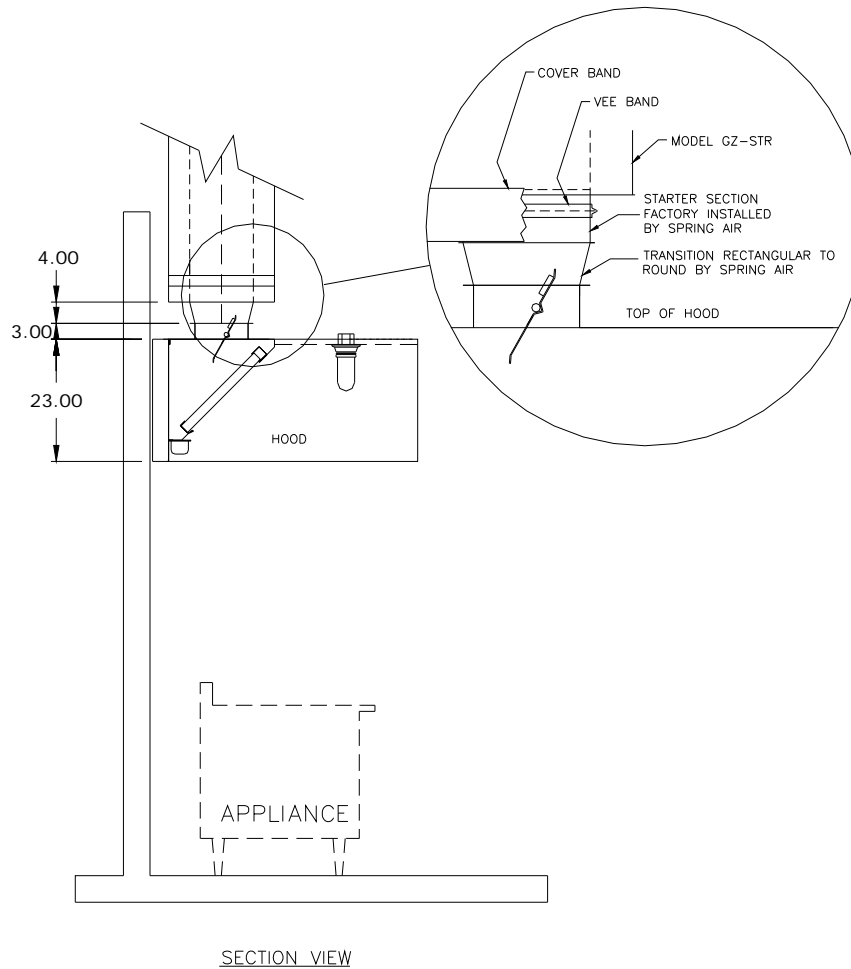

Figure 20
Spring Air FD Hood, with Zoneflow and J-Couple and GZ Starter Piece

The Spring Air Systems FD hood duct collar has a round starter piece welded to the top of the combination Zoneflow and Exhaust Fire Damper by the factory. Make the V band connection per the joint assembly instructions and then wrap the joint with provided insulation and enclose the insulation in a wide cover band. The authority having jurisdiction may require insulation and wide cover band wrapped around the Zoneflow Exhaust Fire Damper from the top starter piece to the roof of the hood.

NOTE: NORMALLY THE INSULATION AND DRAW BANDS ARE NOT INSTALLED UNTIL AFTER ALL OF THE DUCT INCLUDED VEE BANDS ARE COMPLETE AND NOT FURTHER ADJUSTMENTS ARE REQUIRED.

CLEANING & FIRE SUPPRESSION:

Automatic hot water/detergent cleaning and fire suppression systems can be integrated into a Model GZ grease duct system by using various Model GZ components which are readily available (or by request sections can be factory fit) with threaded pipe nipples, couplings, etc. Van-Packer does not provide, design, specify, etc. wash down and fire suppression equipment or systems. Automatic cleaning systems typically provide hot water (approx. 160° F) and detergent injected by conventional hardware utilizing



“jet spray” characteristics in a fashion such that the entire grease duct system can be cleaned daily in order to remove grease and oily residues. Due to the frequency of cleaning cycles and the volume of hot water/detergent mixture, automatic cleaning implies that the grease duct system’s drains may need to be piped to a properly equipped facility drain rather than individual grease traps of a fixed bucket size which are typically used for manually cleaned grease duct systems. Reference NFPA 96 for additional cleaning system requirements and check with local codes and authorities having jurisdiction for requirements governing the plumbing of and draining of waste waters containing cleaning agents, grease, etc. Cleaning systems must be installed in accordance with the terms of their listing and according to the manufacturer’s instructions.

Figure 21

FN Hood GZ STARTER looking up from inside hood with duct fire suppression nozzle

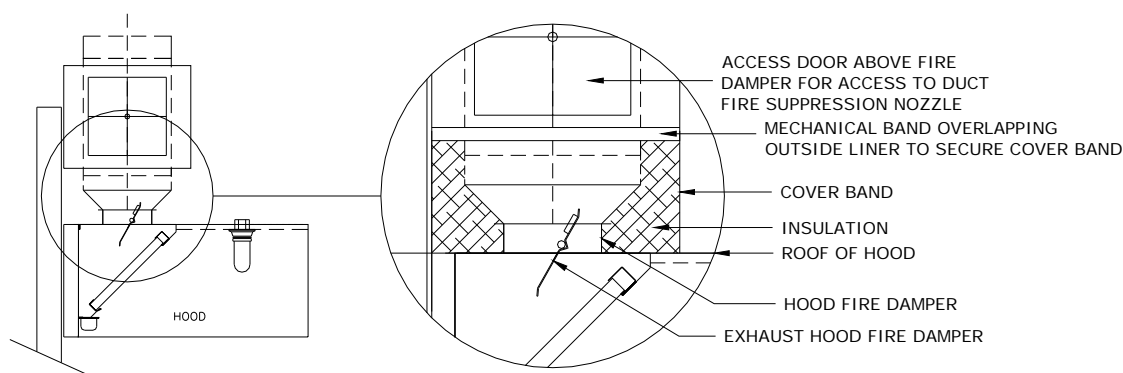

Figure 22

FD Hood with exhaust fire damper showing access door above starter piece

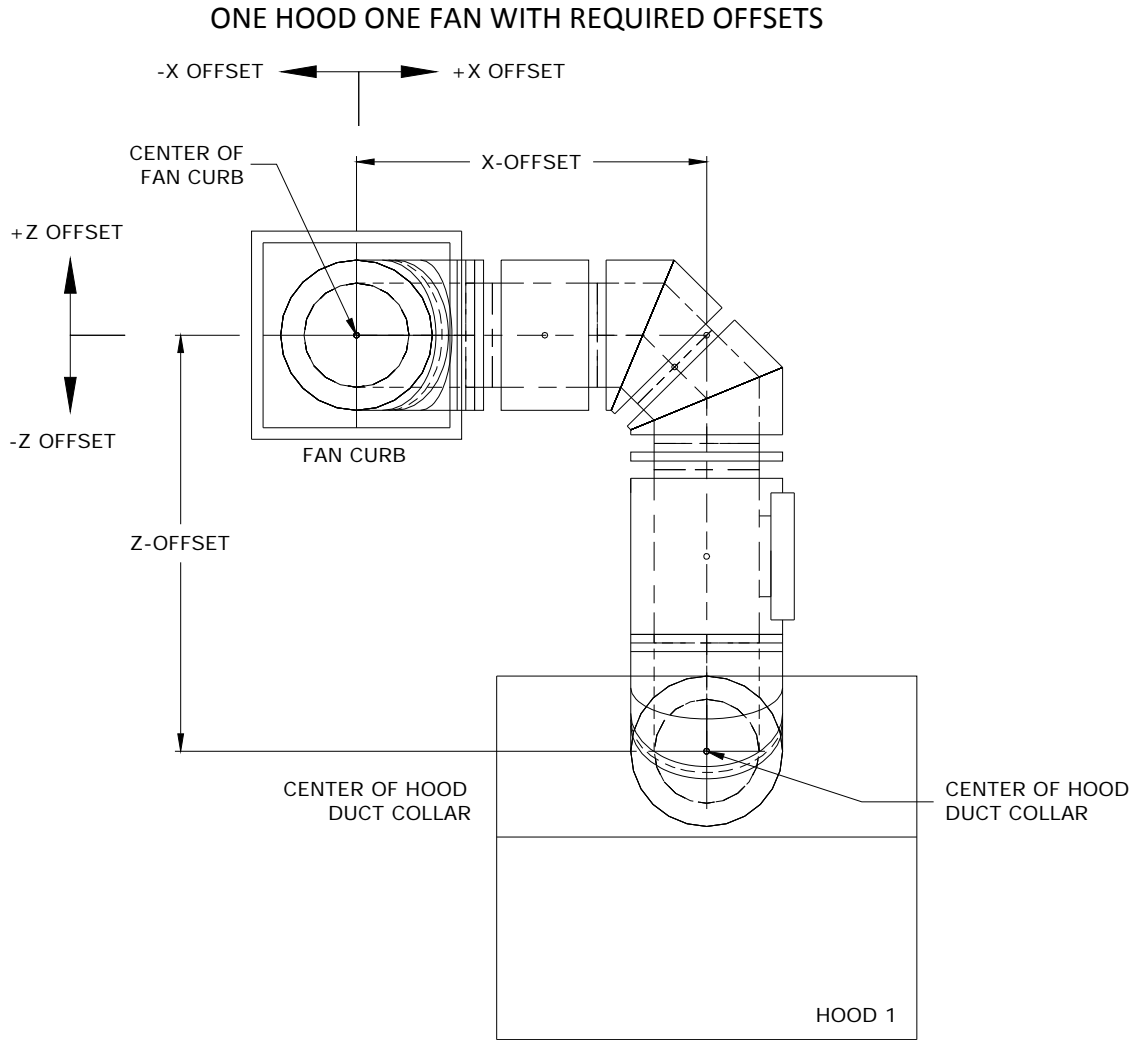

Figure 23
ONE HOOD ONE FAN WITH REQUIRED OFFSETS
Offset plan view of one hood one exhaust fan

WARNING

Code compliant clearances must be observed for a component or assembled components which are not insulated, and enclosed by a shell, cover, or draw band. Code compliant clearances must also be observed where components or portions of components are in direct contact with the liner (I.D.) and protrude past the duct shell, cover, or draw band. When installed in accordance with these instructions and applicable codes, Model GZ grease ducts are equivalent to field fabricated two hour fire rated grease duct enclosure systems. Do not apply wraps or enclosure materials in direct contact with Model GZ components in a manner as to have the Model GZ duct act as the supporting member or structure for the supplemental wrap or enclosure. Model GZ has not been tested, listed, designed, etc. to carry extra weight.

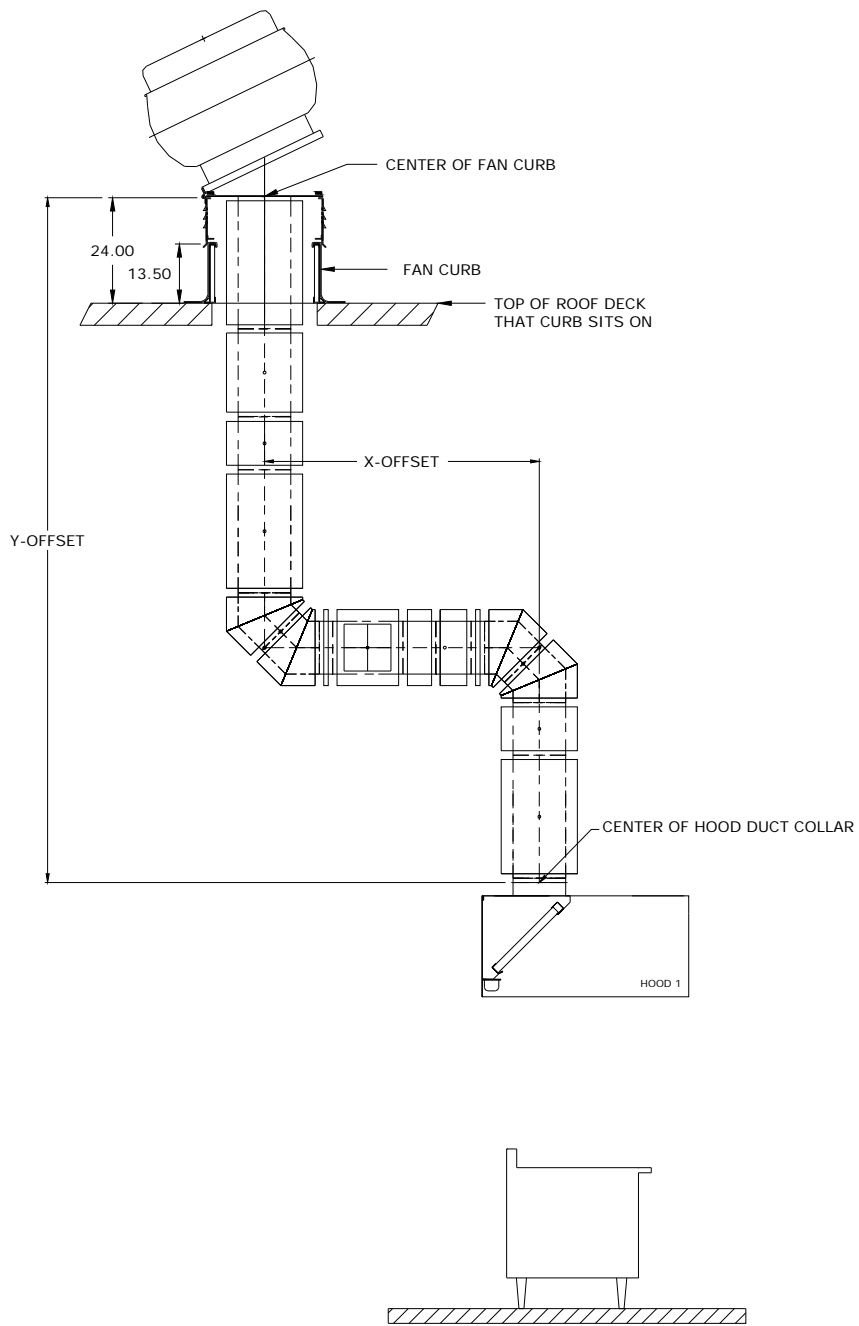

Figure 24
ONE HOOD ONE FAN WITH REQUIRED OFFSETS
 Section View Offset One Hood/One Fan Section Offset Section View

TWO HOODS ONE FAN WITH REQUIRED OFFSETS

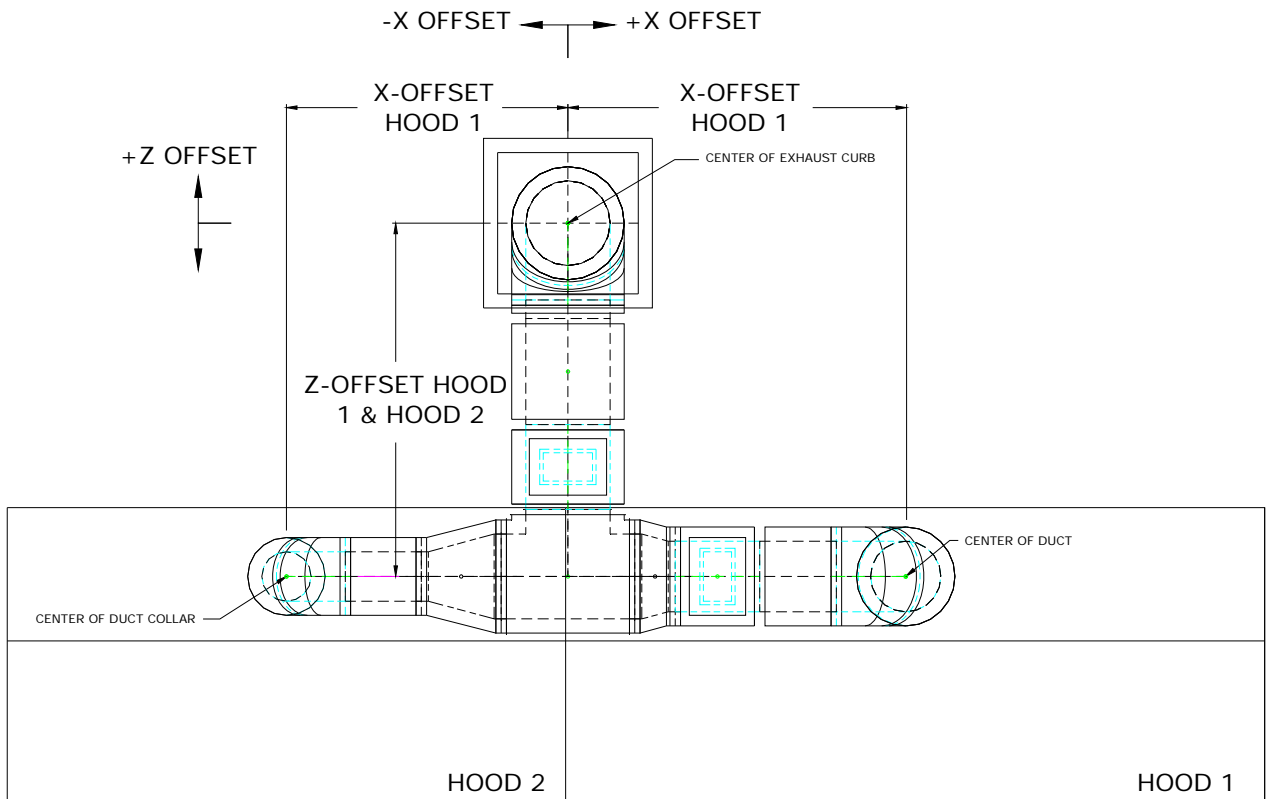

Figure 25
TWO HOODS ONE FAN WITH REQUIRED OFFSETS
Plan View

The hood and fan, offsets shown about is another common commercial kitchen two hood and one exhaust fan layout. Normally the two hoods are joined by a common duct with a tee in the middle and a single duct entering the exhaust fan. The exhaust fan may not be located directly over the hoods because of obstructions such as columns, joist, etc. The GZ ductwork would require one access door above the tee. If the hoods were supplied with exhaust fire dampers an access would be required 18" from the hood fire dampers in the horizontal duct for each hood.

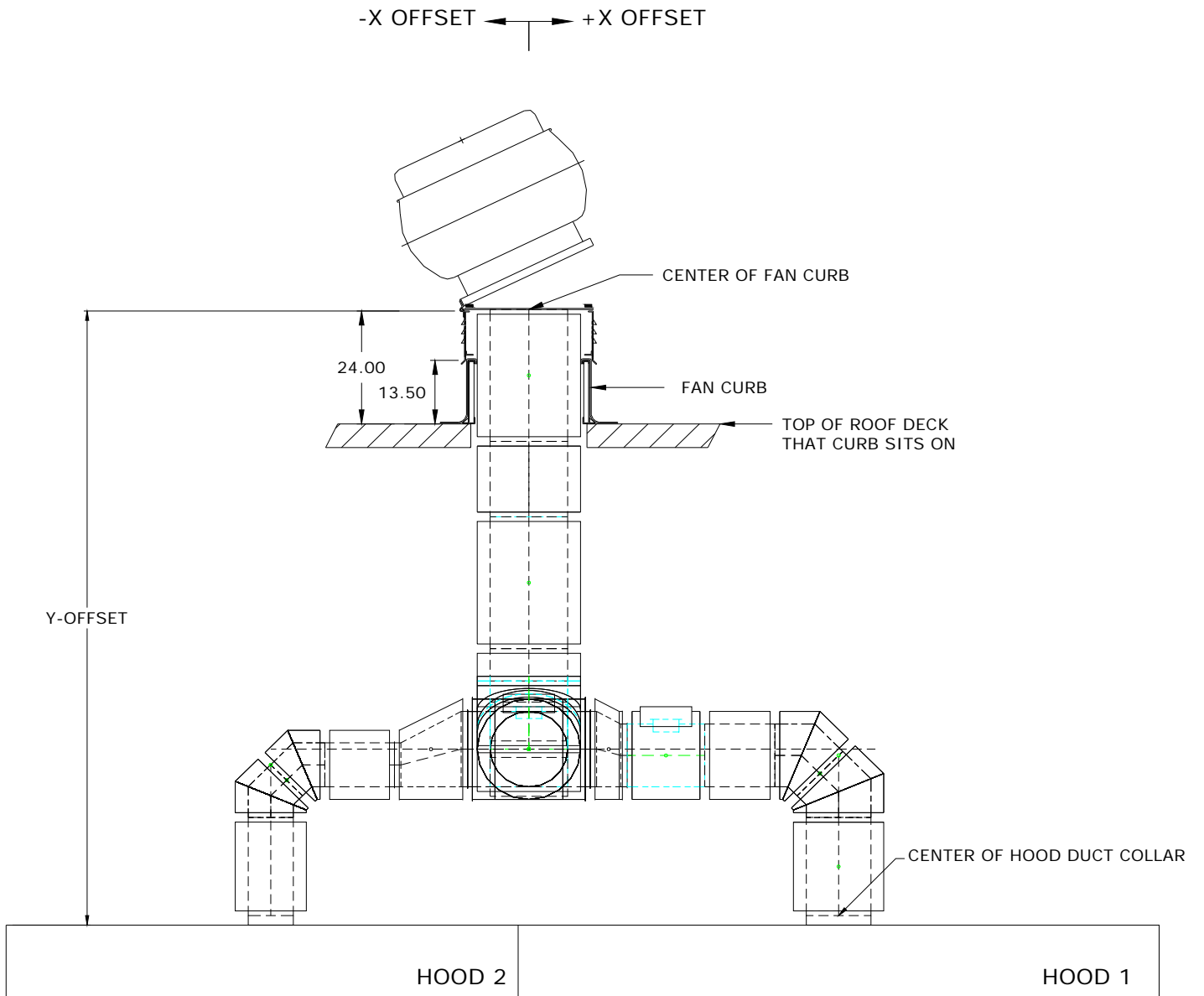

Figure 26
TWO HOODS ONE FAN WITH REQUIRED OFFSETS
Section View Offset

THREE HOODS ONE FAN WITH REQUIRED OFFSETS

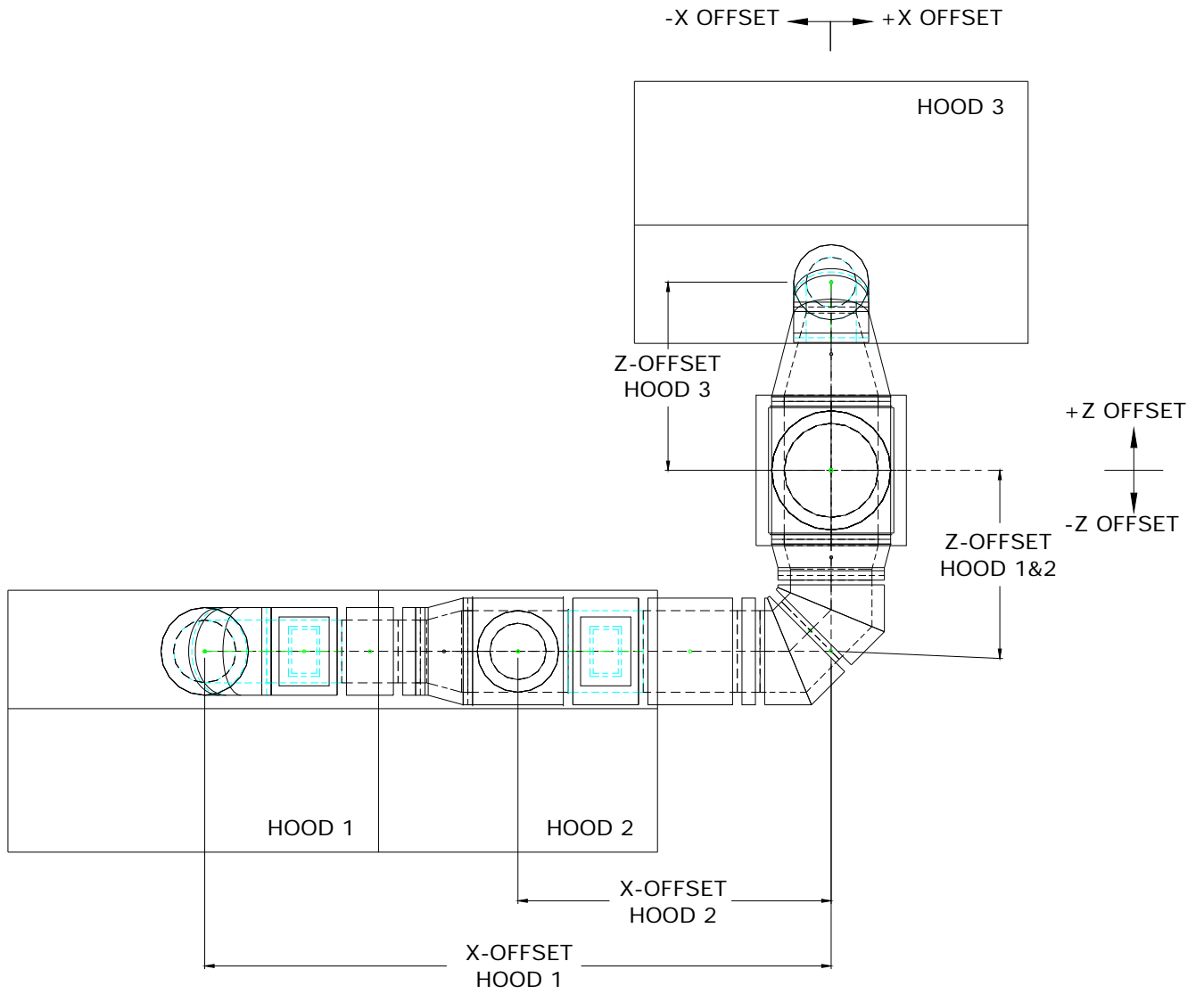

Figure 27
THREE HOODS ONE FAN WITH REQUIRED OFFSETS
Plan View Offset

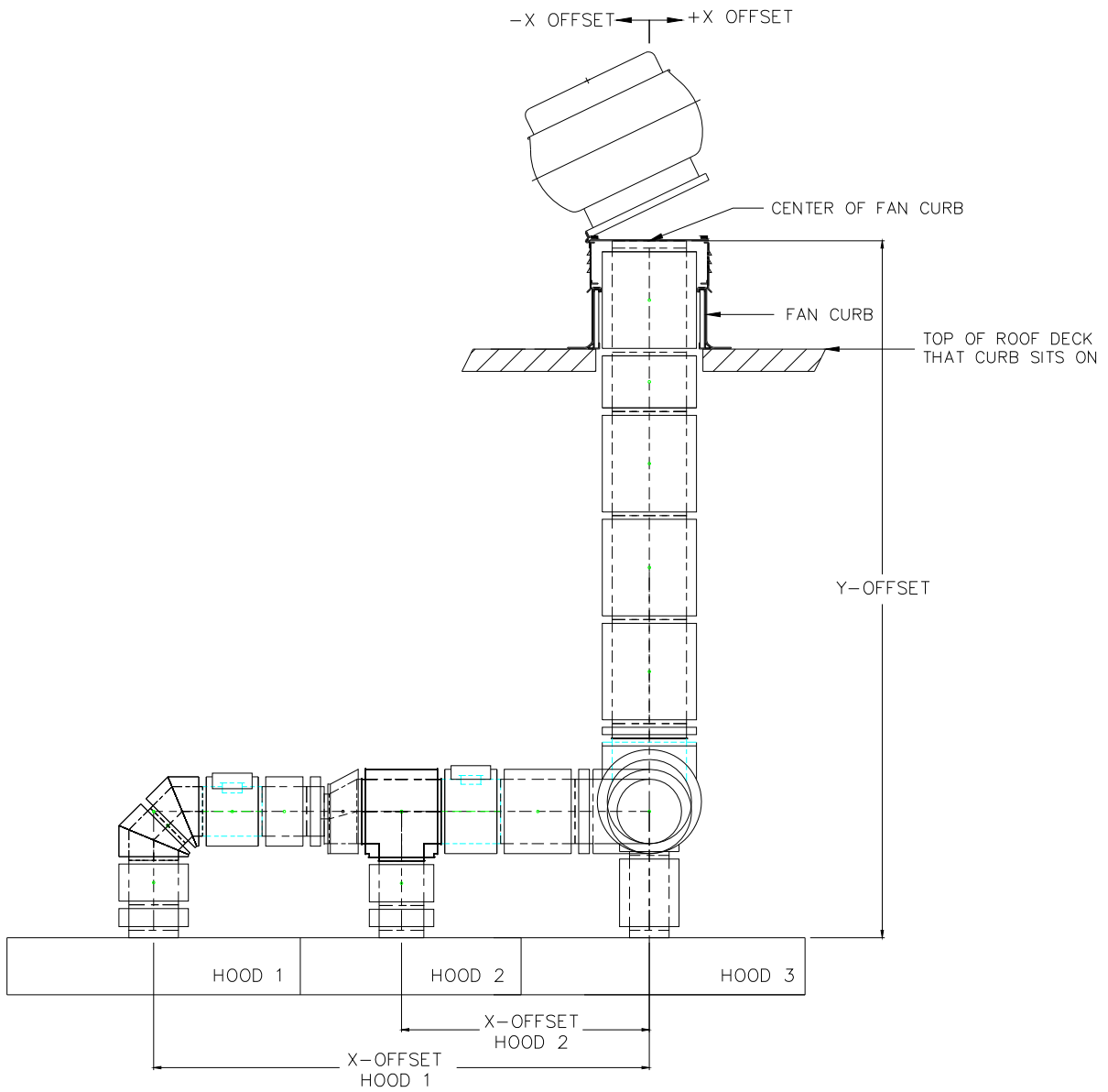
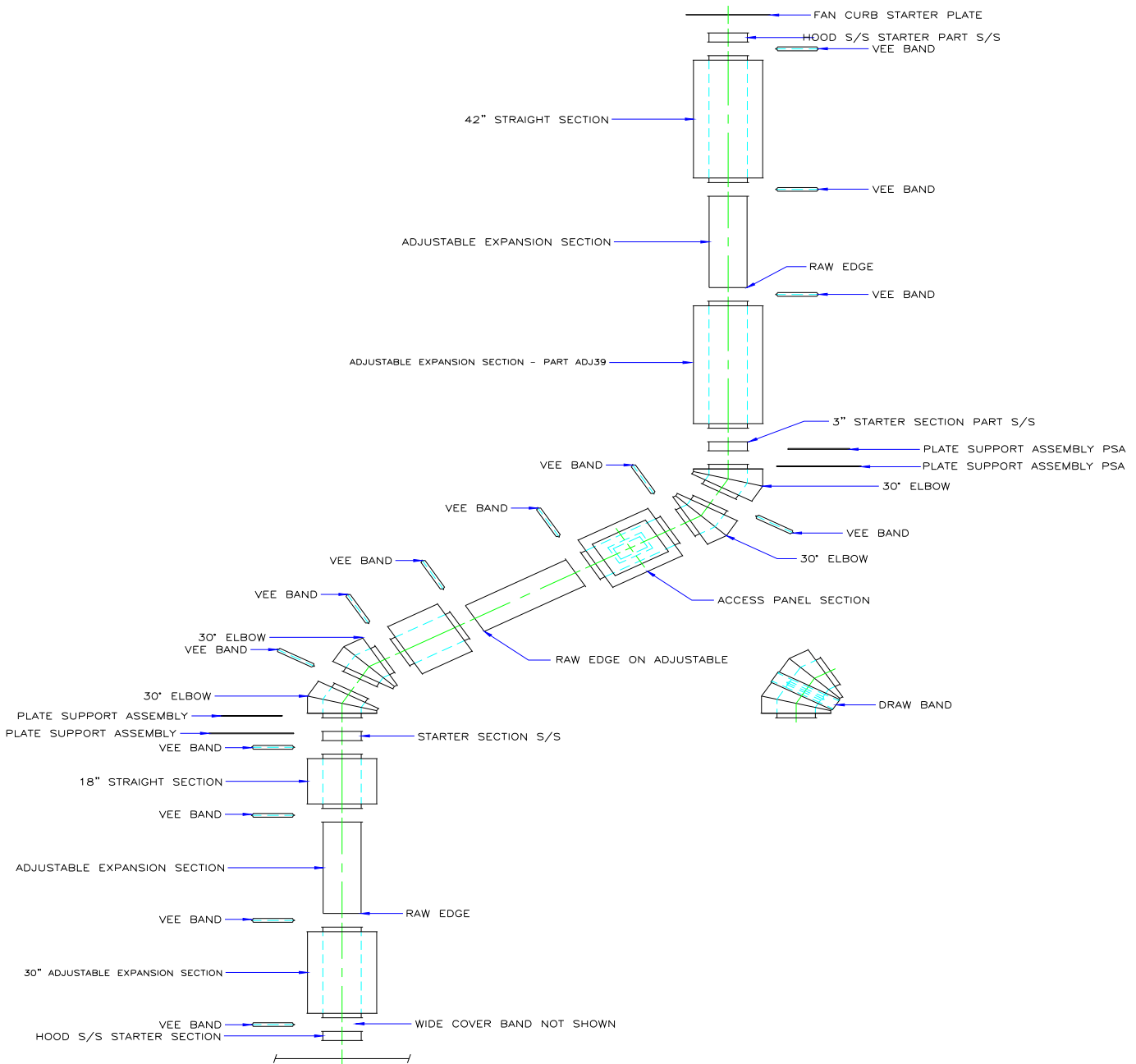

Figure 28
THREE HOODS ONE FAN WITH REQUIRED OFFSETS
Elevation View Offset

TYPICAL DUCTWORK RUN SHOWING COMPONENTS



*Figure 29
Typical Ductwork layout showing all components*

PART IDENTIFICATION:

All of the Van Packer GZ components are not shown in this manual. Refer to the Van Packer GZ Installation Instructions for the complete list of components.

G10STRA30

Refers to a **Model GZ** 10" I.D., 30" long straight section constructed with a 304 S.S. liner and an aluminized steel shell.

- G = Model GZ Product Code
- 10 = Section I.D.
- STR = Part Code (Straight Section)
- A = Liner/Shell Code (304 S.S. Liner/ALZ Steel Shell)
- 30 = Qualifier Code (30" Long)

LINER/SHELL MATERIAL CODES

- A = 304 S.S. Liner/ALZ Steel Shell
- C = 316 S.S. Liner/316 S.S. Shell
- E = 316 S.S. Liner/304 S.S. Shell
- H = 304 S.S. Liner/430 S.S. Shell

G12BTTJ08

Refers to a **Model GZ** 12" I.D. bodied boot tee section with an 08" I.D. projection constructed with a 316 S.S. liner and a 430 S.S. shell.

- G = Model GZ Product Code
- 12 = Tee Body I.D.
- BTT = Part Code (Boot Tee Section)
- J = Liner/Shell Code (316 S.S. Liner/430 S.S. Shell)
- 08 = Qualifier Code (08" I.D. Projection)

LINER/SHELL MATERIAL CODES

- B = 316 S.S. Liner/ALZ Steel Shell
- D = 304 S.S. Liner/304 S.S. Shell
- F = 304 S.S. Liner/316 S.S. Shell
- J = 316 S.S. Liner/430 S.S. Shell

WEIGHT OF GZ DUCTWORK

I.D.	O.D.	Approx. Assembled Weight per Foot	I.D.	O.D.	Approx. Assembled Weight per Foot
6"	14"	14.6 lbs	20"	28"	37.6 lbs
7"	15"	15.9 lbs	22"	30"	41.0 lbs
8"	16"	17.3 lbs	24"	32"	44.0 lbs
9"	17"	18.7 lbs	26"	34"	47.0 lbs
10"	18"	20.1 lbs	28"	36"	50.0 lbs
12"	20"	22.9 lbs	30"	38"	53.0 lbs
14"	22"	25.7 lbs	32"	40"	56.3 lbs
16"	24"	28.5 lbs	34"	42"	59.4 lbs
18"	26"	31.4 lbs	36"	44"	62.4 lbs

CHART No. 1

DUCT SECTIONS AND FITTINGS:

STARTER SECTION – PART S/S

The starter section is a short liner piece flanged on each end. This part when used as an adapter is intended to have one end connected to a hood, duct/transition by others, fan unit, etc. according to applicable methods as described by NFPA and then allow for a regular connection of a Model GZ component to the other flanged end. This part may also be used to ease the assembly & installation of supports (PLS, WSA, GAR) See installation examples. In some instances an additional wrap and banding (to be by others) at the final connection area may be required to complete a fire rated duct enclosure (refer to applicable codes).

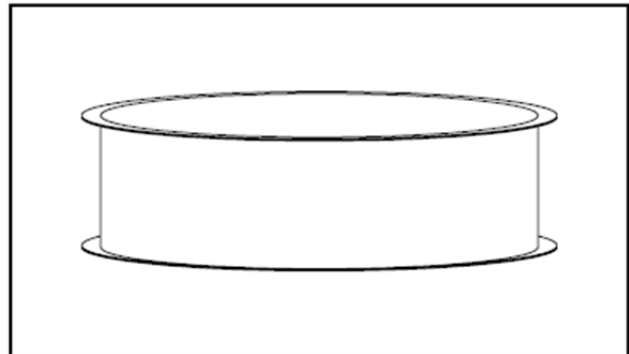
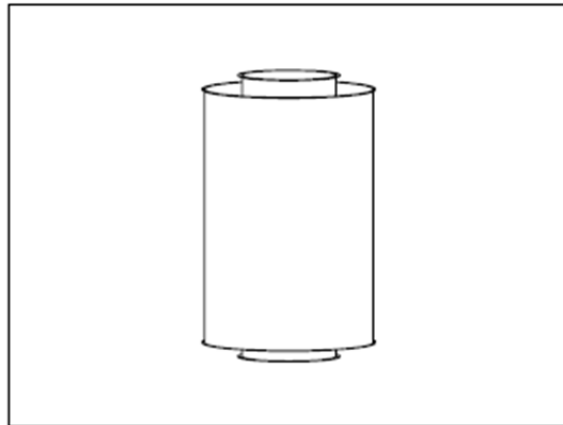

Figure 30
Starter Section

STRAIGHT SECTIONS – PART STR

Straight sections are fixed lengths joined together to comprise desired grease duct runs. These sections may also be equipped (must be factory installed, contact Van-Packer for additional information) with nipples or couplings to accommodate test probes, fire suppression nozzles, etc...



*Figure 31
Straight Section*

ELBOWS – PART **E

Individual elbows and assembled combinations of elbows can be used for changes in duct direction. Elbows must be isolated from the effects of thermal expansion and excessive bending loads.

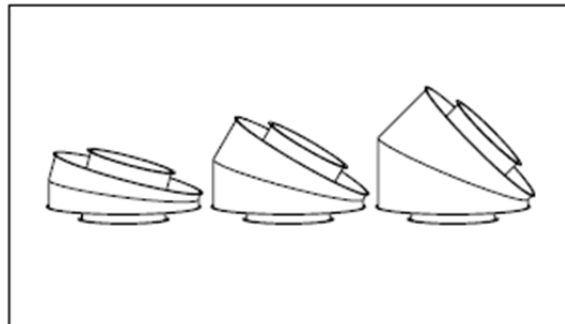

*Figure 32
Elbows*

90° WYE SECTION – PART WYE

The 90° WYE section can be used for joining duct runs together or to provide cleanout access at a 90° change in direction. 90° WYE sections must be isolated from the effects of thermal expansion and excessive bending loads.

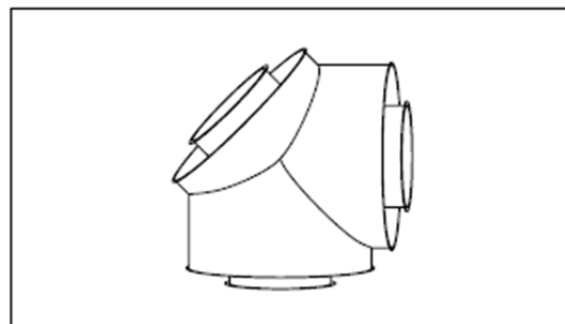

*Figure 33
90 degree WYE Section*

90° CENTERED TEE SECTION – PART 90T

The 90° tee section can be used for joining duct runs together, making 90° changes in direction, and to provide cleanout access. 90° tee sections must be isolated from the effects of thermal expansion and excessive bending loads.

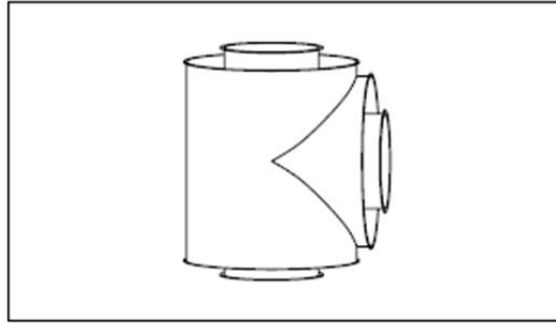

Figure 34
90 degree Tee Section

90° BOOT TEE SECTION – PART BTT

The 90° boot tee section can be used for joining duct runs together, making low resistance 90° changes in direction, and to provide cleanout access. 90° boot tee sections must be isolated from the effects of thermal expansion and excessive bending loads.

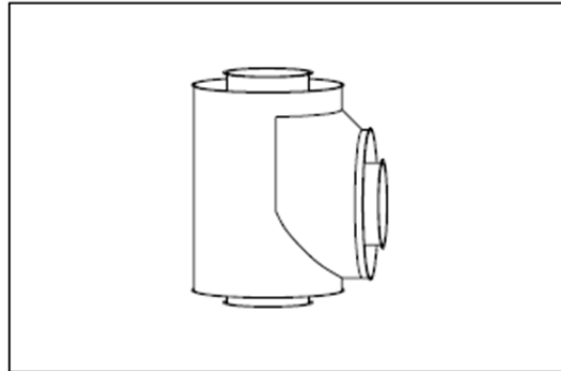

Figure 35
90 degree Boot Tee Section

45° TEE SECTION – PART 45T

The 45° tee section can be used for joining duct runs together, making 45° changes in direction, and the projection is often joined with a 45° elbow to make a low resistance 90° change in direction. 45° tee sections must be isolated from the effects of thermal expansion and excessive bending loads.

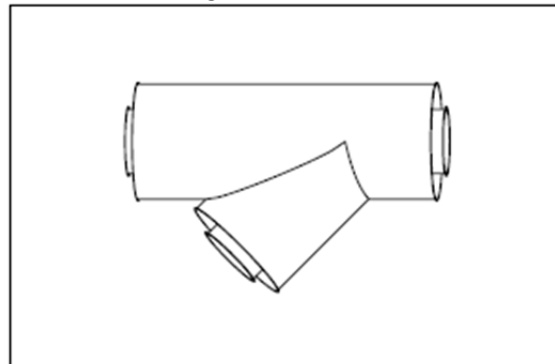
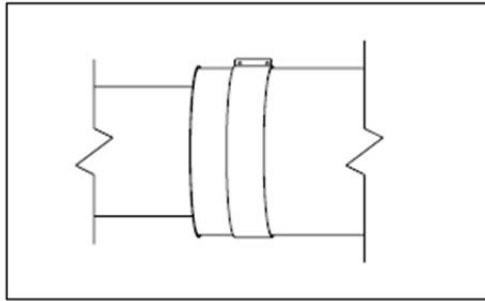

Figure 35
45 degree Tee Section

ABRUPT TRANSITION – PART ATS

This part is used to transition to a different diameter within a short distance. This component used in conjunction with an end cap can be used to reduce the end of a horizontal run (sized to provide 02" between the bottom of the duct and the bottom of the opening) and provide cleanout access. The abrupt transition is comprised of a short transition, insulation strip, and cover. Extreme care should be taken when reducing duct size as the resultant duct resistance may increase. This component is non-load bearing and must be isolated from the effects of thermal expansion and excessive bending loads.



INCREASE DUCT SIZE

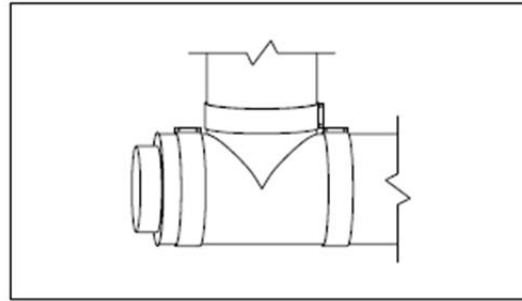

REDUCE FOR CLEANOUT

Figure 36
Abrupt Transitions

INCREASERS – PARTS INC & ECC

These parts are used to transition to different diameters. The standard increaser section, part INC, is a cone shaped design and the eccentric increaser section, part ECC, has been designed to allow for one duct side to remain in line. The eccentric increaser is typically preferred in horizontal installations where the bottom of the duct needs to remain in line to allow for drainage. Extreme care should be taken when reducing duct size as the resultant duct resistance may increase. These components are not intended to be subject to heavy loads.

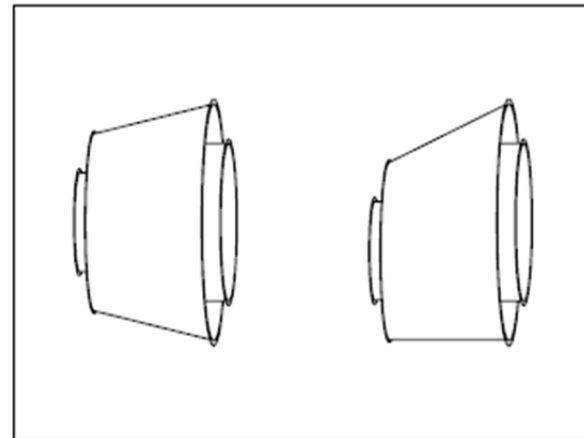

Figure 37
Increases

END CAPS – PARTS CAP & C/D

These parts are used to close off ends of breeching runs, stack risers, and to provide cleanout and inspection access. The end cap with drain (part C/D) may be used at the base of a tee section to provide drainage of a vertical riser and may also be used on tee section projections in horizontal runs for use as access ports for supplemental equipment; e.g., sprinkler heads, etc.

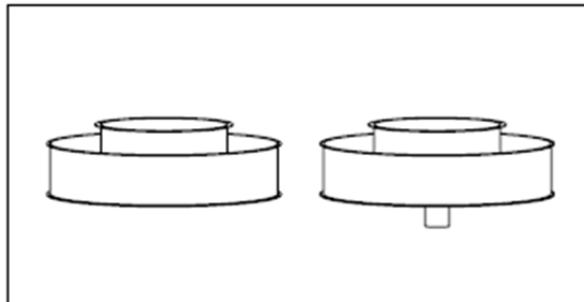

Figure 38
End Caps

DUCT COUPLING AND DRAIN SECTIONS PARTS DCS & DDS

The duct coupling section (part DCS) may be used to provide necessary access ports for supplemental equipment; e.g., sprinkler heads, etc. The duct drain section (part DDS) is intended for use as a horizontal drain section. Part DDS is equipped with an internal dam near the drain coupling.

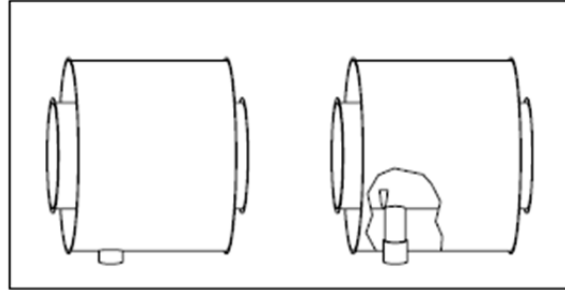

Figure 39
Duct couples and drains

ACCESS PANEL SECTION – PART APS

This part is intended to be used for clean out access. When the access panel section is installed in a horizontal position, it must be orientated in accordance with applicable codes. Using the included fasteners, secure the liner door. Next, set the insulation sheet against the liner door. Last, using the included fasteners secure the shell door.

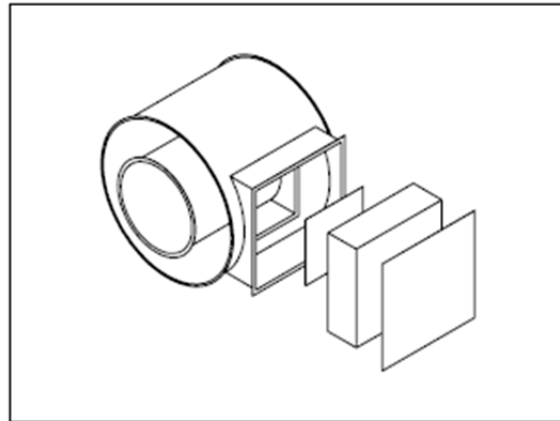

Figure 40
Access Panels

COVER PLATE – PART CVR

This part is intended to be used to close off the space between the liner and the shell. Use the cover plate for a uniform shell appearance. The cover plate is comprised of (2) half rings and can be held in place against the rolled flange of a component shell using a half draw band.

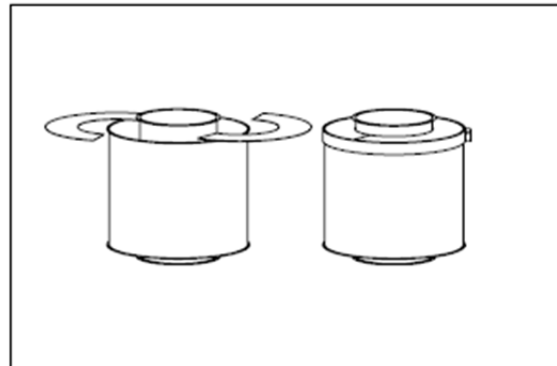

Figure 41
Cover Plates

EXHAUST DUCT DIAMETER VAN PACKER CONNECTED TO SPRING AIR HOODS

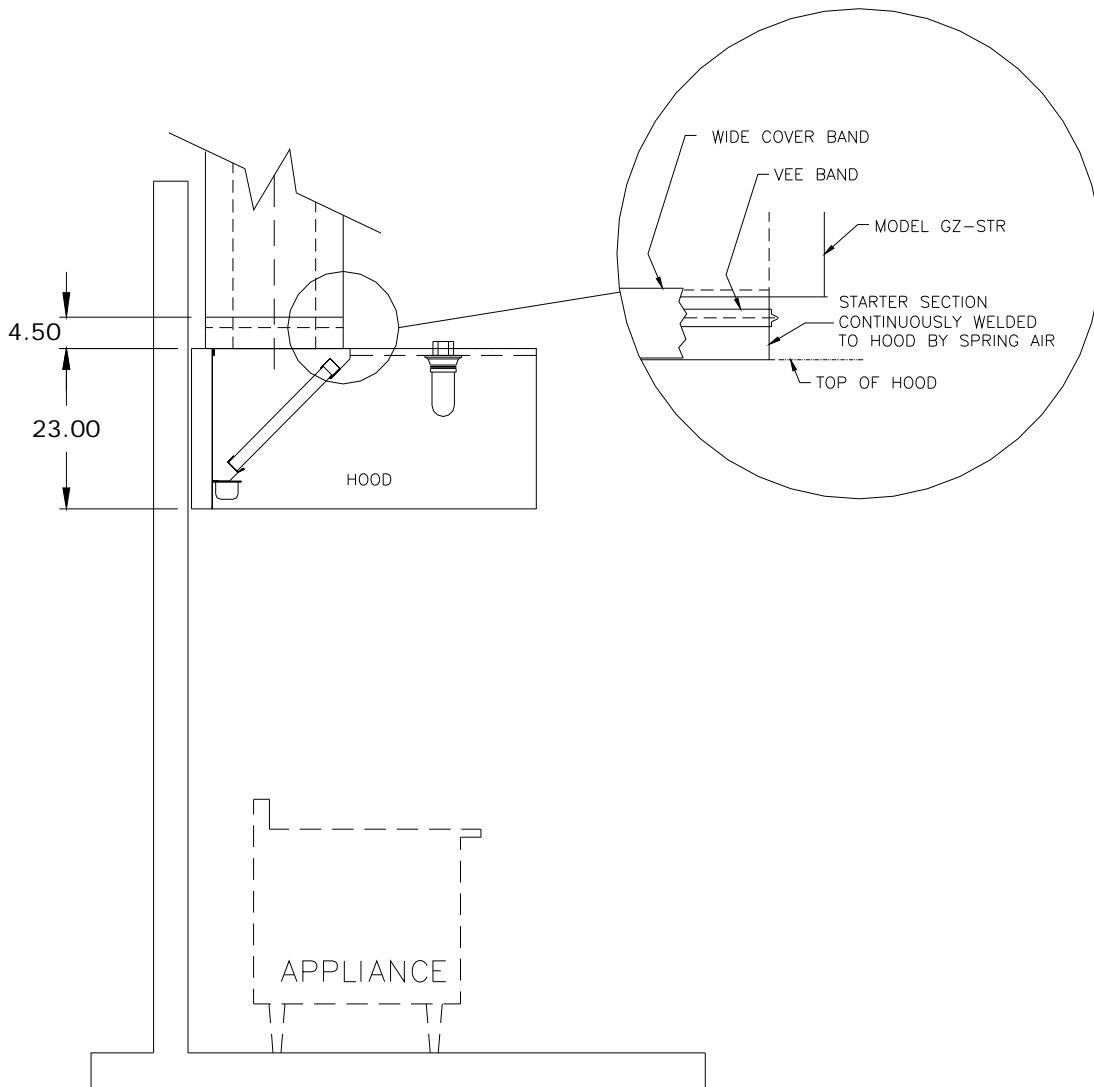

Figure 42
Spring Air FN Hood with starter section

Design Exhaust Duct Velocity = 1800 fpm

Duct Diameter (inches) = 0.319 x Square Root of CFM

The Charts below are for all hood models starting with the prefixes below.

Round Up to nearest I.D. from Van Packer duct size chart.

Van Packer Available Duct Sizes		
I.D. (inches)	O.D. (inches)	Maximum CFM base on 1800fpm
6	14	353
7	15	481
8	16	628
9	17	795
10	18	982
12	20	1414
14	22	1924
16	24	2513
18	26	3181
20	28	3927
22	30	4752
24	32	5655
26	34	6637
28	36	7697
30	38	8836
32	40	10053
34	42	11349
36	44	12723

CHART No. 2

Maximum Duct Diameter for each “B” style Hood

Hood Model Number	Maximum Duct Size (inches)
FNB & FDB	16
FCNB & FCDB	16
DNBF & DDBF	12
DNB & DDB	10
HNB & HDB	12
CNB & CDB	12

CHART No. 3

Maximum Duct Diameter for each “S” style Hood
5 feet and under length

FNS& FDS	10
FCNS & FCDS	10
DNS & DDS	10
HNS & HDS	12
CNS & CDS	12

CHART No. 4

Maximum Duct Diameter for each "S" style Hood
Over 5 feet length

FNS& FDS	16
FCNS & FCDS	16
DNS & DDS	10
HNS & HDS	12
CNS & CDS	12

CHART No. 5

Maximum Duct Diameter for each "BS" style Hood
5 feet and under length

FNBS& FDBS	10
FCNBS & FCDBS	10
DNBS & DDBS	10
HNBS & HDBS	12
CNBS & CDBS	12

CHART No. 6

Maximum Duct Diameter for each "BS" style Hood
Over 5 feet length

FNBS& FDBS	16
FCNBS & FCDBS	16
DNBS & DDBS	10
HNBS & HDBS	12
CNBS & CDBS	12

CHART No. 7

Once the Diameter is too large and addition round duct collar is required. Recalculate the two round duct diameters based on half the required CFM

For example if the hood is a DNBF requiring 2500 CFM the duct diameter required would be 16 inch. From Chart No 2 the hood can only fit a 12" diameter duct so split the CFM in half and recalculate. A hood DNBF requiring 2 ducts at 1250 CFM each would require 2 ducts at 12" diameter on the top of the exhaust hood.

MAXIMUM DUCT DIAMETER – FOR SERIES XF-B SPUN ALUMINUM EXHAUST FANS

XF-BXXXX is the prefix based on class type of fan. Regardless the maximum duct diameter is the same.

EX-B Model	Bottom of fan Square (inches)	Roof Curb Model Number	Roof Opening Square (inches)	Maximum duct diameter (inches)
XX100	18	RCG-16	13.5	N/A*
XX120	20	RCG-18	15.5	7
XX135	20	RCG-18	15.5	7
XX150	24	RCG-22	19.5	10
XX165	24	RCG-22	19.5	10
XX180	30	RCG-28	25.5	16
XX195	30	RCG-28	25.5	16
XX210	30	RCG-28	25.5	16
XX225	30	RCG-28	25.5	16
XX245	30	RCG-28	25.5	16
XX270	36	RCG-34	31.5	22
XX300	36	RCG-34	31.5	22
XX330	42	RCG-40	37.5	28
XX365	42	RCG-40	37.5	28
XX402	48	RCG-46	43.5	34

1. N/A* - The XX100 fan roof opening is too small for any Van Packer exhaust duct. The next size roof curb must be used with a curb adapter between the top of the curb and the exhaust fan.
2. When the duct diameter is too small for the exhaust fan curb there are two options. Select a larger fan with a bigger roof curb or provide a larger curb that fits the duct diameter selected and add a curb adapter between the top of the curb and bottom of the exhaust fan.

SUPPORTING THE PRE-ENGINEERED DUCTWORK

NOTE: The structural engineer for the project should select support member channels, beams, rods, wires/cables, etc. and joining methods in accordance with Good Engineering Practices to suite each specific application. Van-Packer accepts no responsibility for the design and/or modification of buildings to accept required support framing, anchoring methods, etc. as a result of load reactions as determined by the structural engineer. If support members, etc. are being welded near the grease duct it is imperative to protect the duct from any welding splatter. Hot weld splatter could burn holes through the grease duct jeopardizing its fire, gas, & liquid containment integrity.

PLATE SUPPORT ASSEMBLY – PART PLS

Plate support assemblies are used for vertical & horizontal (breeching anchor) structural support applications. The PLS, in conjunction with field fabricated support members from the PLS to the building structure, is intended to provide rigid (static) support locations. These rigid support locations are intended to withstand the weight of duct components, forces from thermal expansion & exhaust velocities, etc. The PLS is comprised of (1) two-piece square support plate and (1) two-piece round clamp flange.

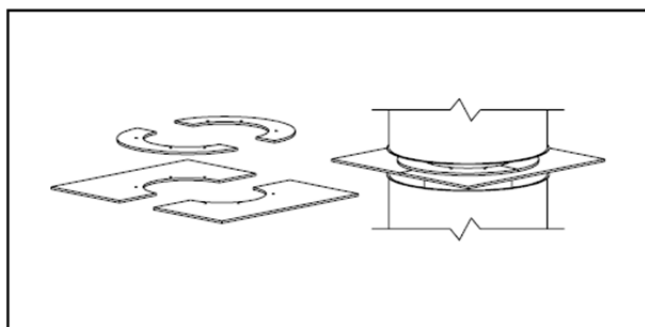

Figure 43
Plate Support Assembly

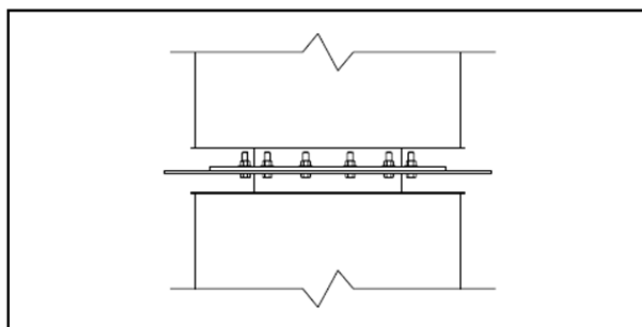
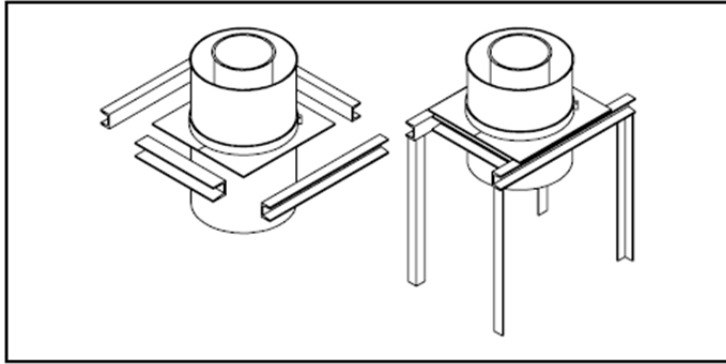

Figure 44
Elevation View Plate Support Assembly

The square plate supports used in both the horizontal and vertical planes are recommended to be installed before every change in direction, at the bottom of risers, in the horizontal between hoods ducted together, to anchor both sides of an expansion joint, and at the top and bottom of an offset. The Plate Support Assembly typically consists of following parts; ½ draw band, wide cover band, 3” starter, (1) two-piece square support plate and (1) two-piece round clamp flange. For ducts that are under 20” diameter use a 3” starter piece and for duct 20” and greater diameter use a quantity of 2 – 3” starter pieces and quantity of two wide cover bands.

Typical completed support assembly by installing contractors. Do not anchor plate supports or plate support framing into combustible material. Support framing is not supplied by Spring Air Systems Inc.

Using one to two starters to install a Plate Support is not required by the listing. We recommend the starters to make it easier to install the Plate Support and make the installation faster.



*Figure 45
Plate Support Framing by Installing Contractor*

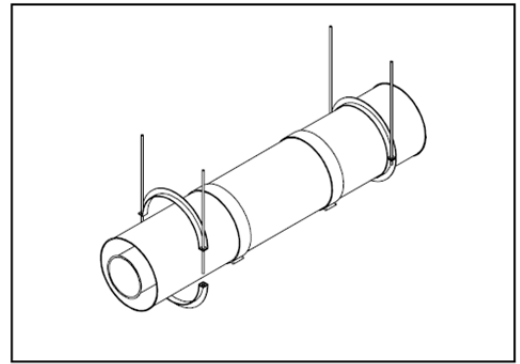
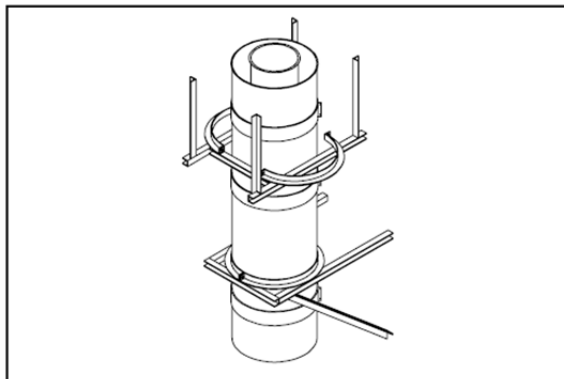

*Figure 46
Full Angle Horizontal Rings*

FULL ANGLE RING

A full angle ring (Part Far) is recommended every 7'0" on horizontal runs and at each clean out. Full angle rings, in conjunction with supports rods or other field fabricated support members from the FAR attached to the building structure, are intended to support the weight of horizontal assembled duct lengths and also to maintain alignment as the duct expands and contracts. The FAR is comprised of (2) half rings and when bolted together is a slight clearance fit to the duct. Position the FAR away from draw bands & covers as to allow for the unrestricted expansion and contraction of the duct system. FAR's cannot be installed over draw bands or variable/adjustable expansion section covers.

FULL ANGLE RING – PART FAR



*Figure 47
Full Angle Rings with field fabricated supports*

Full angle rings, in conjunction with field fabricated support members from the FAR attached to the building structure, are intended to laterally brace the vertical assembled duct lengths from wind loads and to also maintain alignment as the duct expands and contracts. The FAR is comprised of (2) half rings and when bolted together is a slight clearance fit to the duct. Position the FAR away from draw bands & covers as to allow for the unrestricted expansion and contraction of the duct system. FAR's cannot be installed over draw bands or variable/adjustable expansion section covers.



Figure 48
Adjustable Expansion Section with
Horizontal Support Plate



Figure 49
Vertical Support Plate under offset

SYSTEM INSTALLATION SUPPORT EXAMPLES

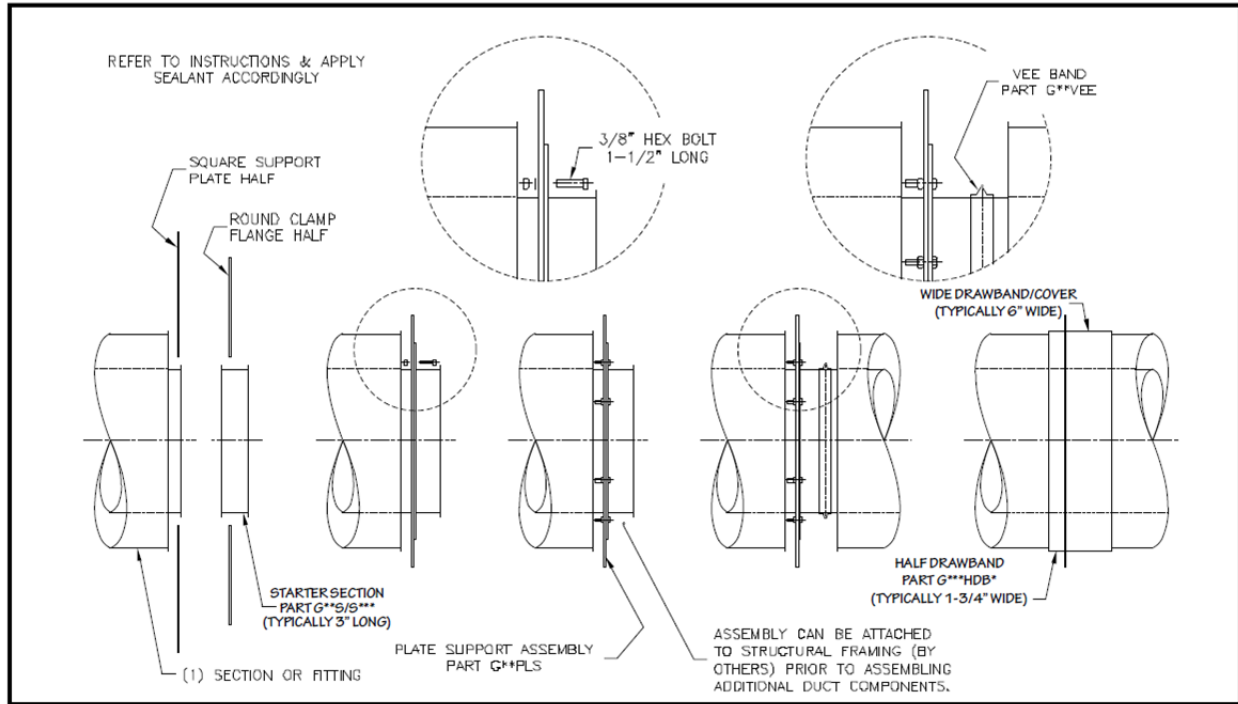

Figure 50
Plate Support Assemblies Starter Section

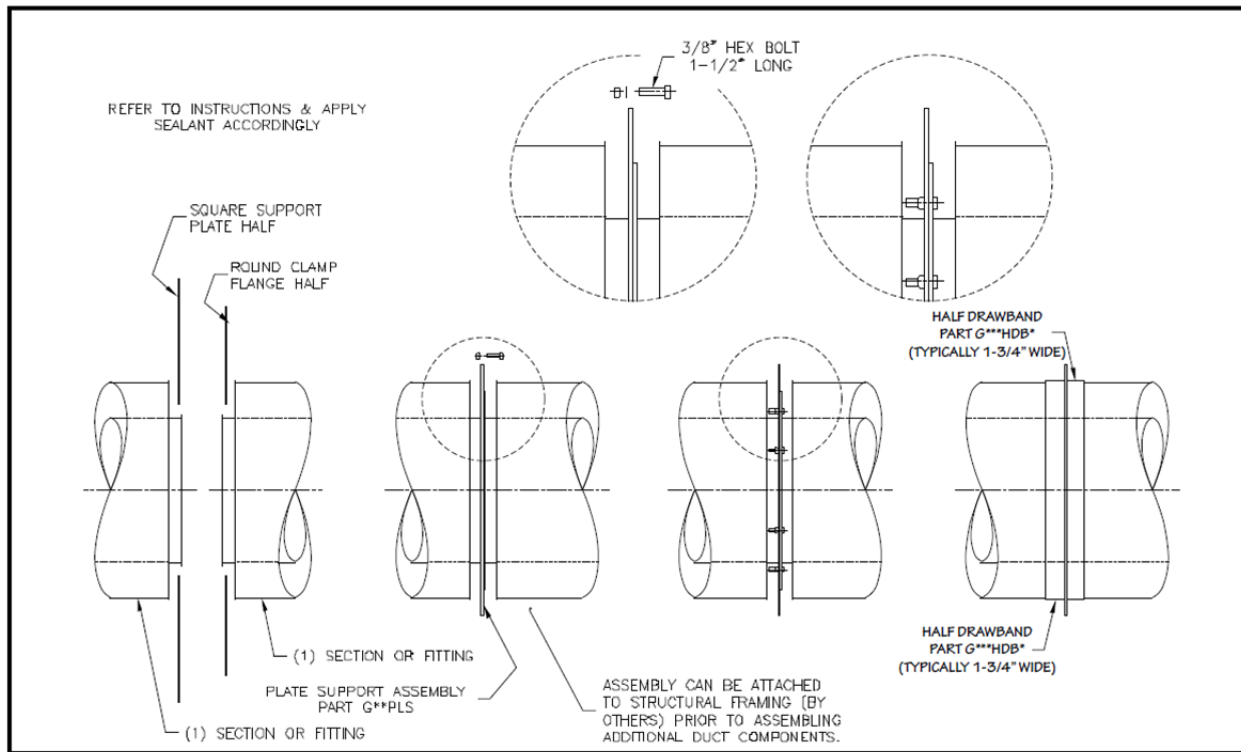

Figure 51
Plate Support Assemblies without Starter Section

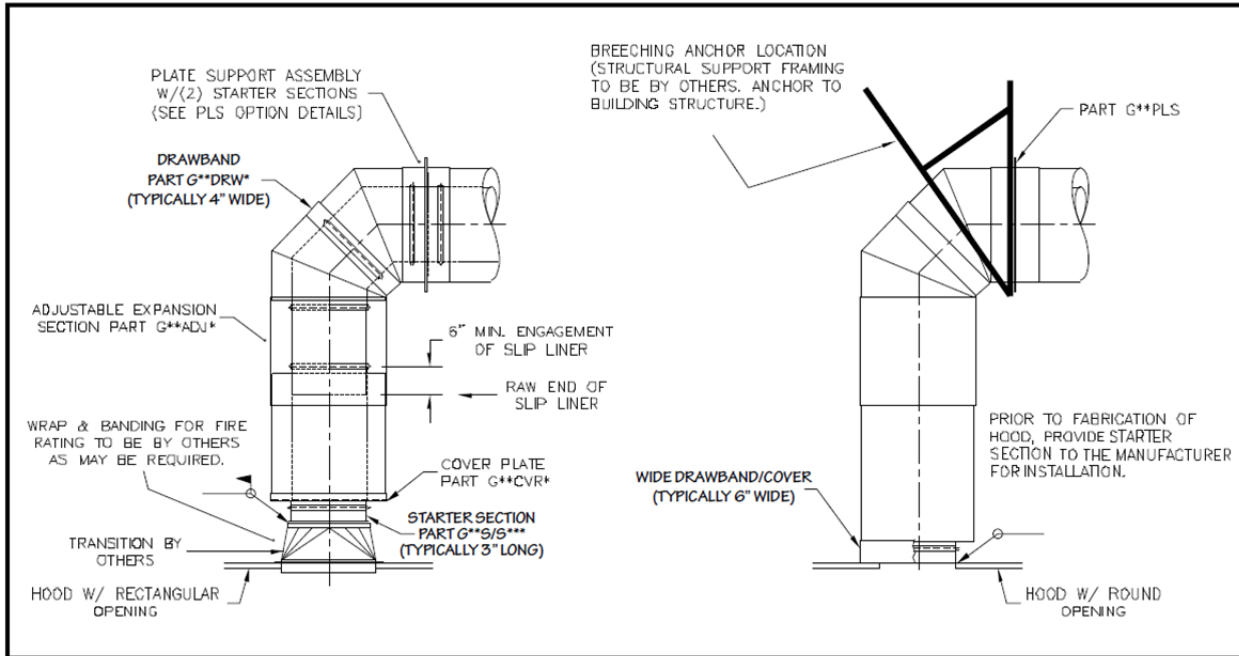

Figure 52
Typical Connections to Transitions/Hoods

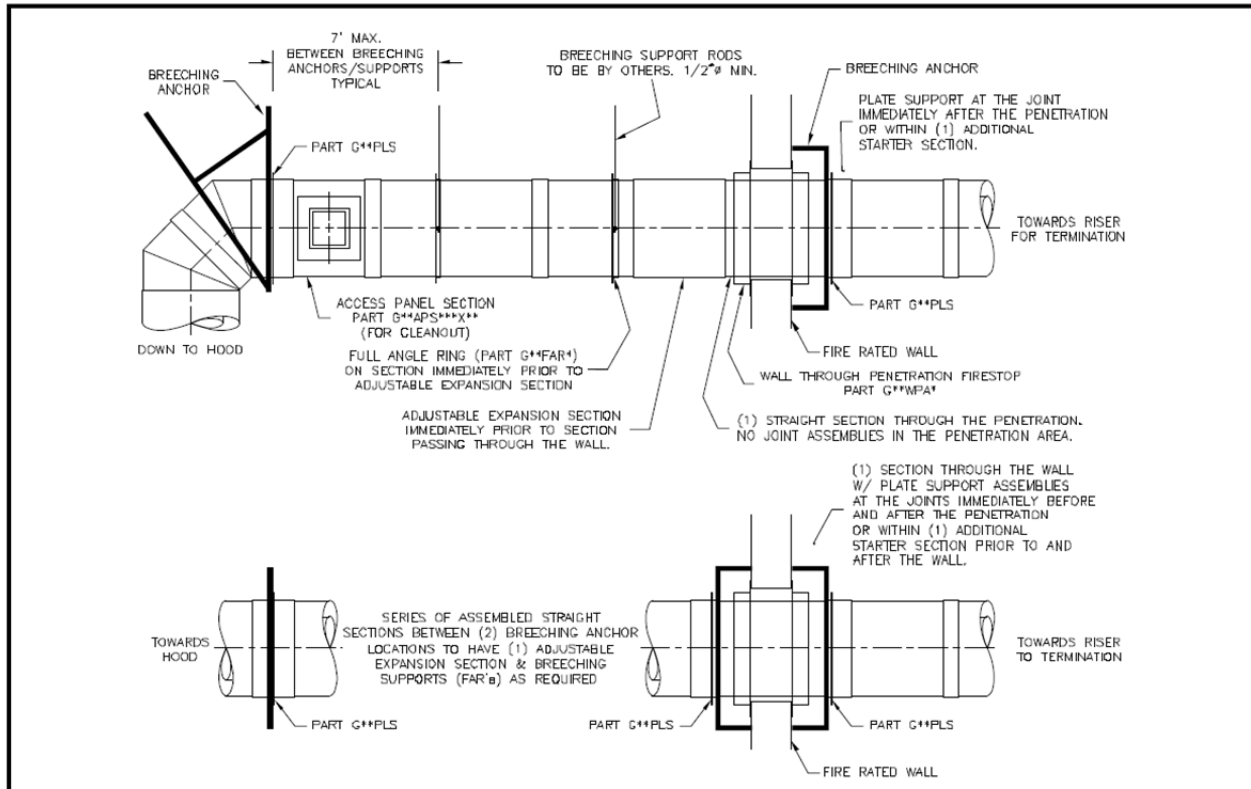

Figure 53
Typical Support Locations for Breaching and Wall through Penetrations Firestops

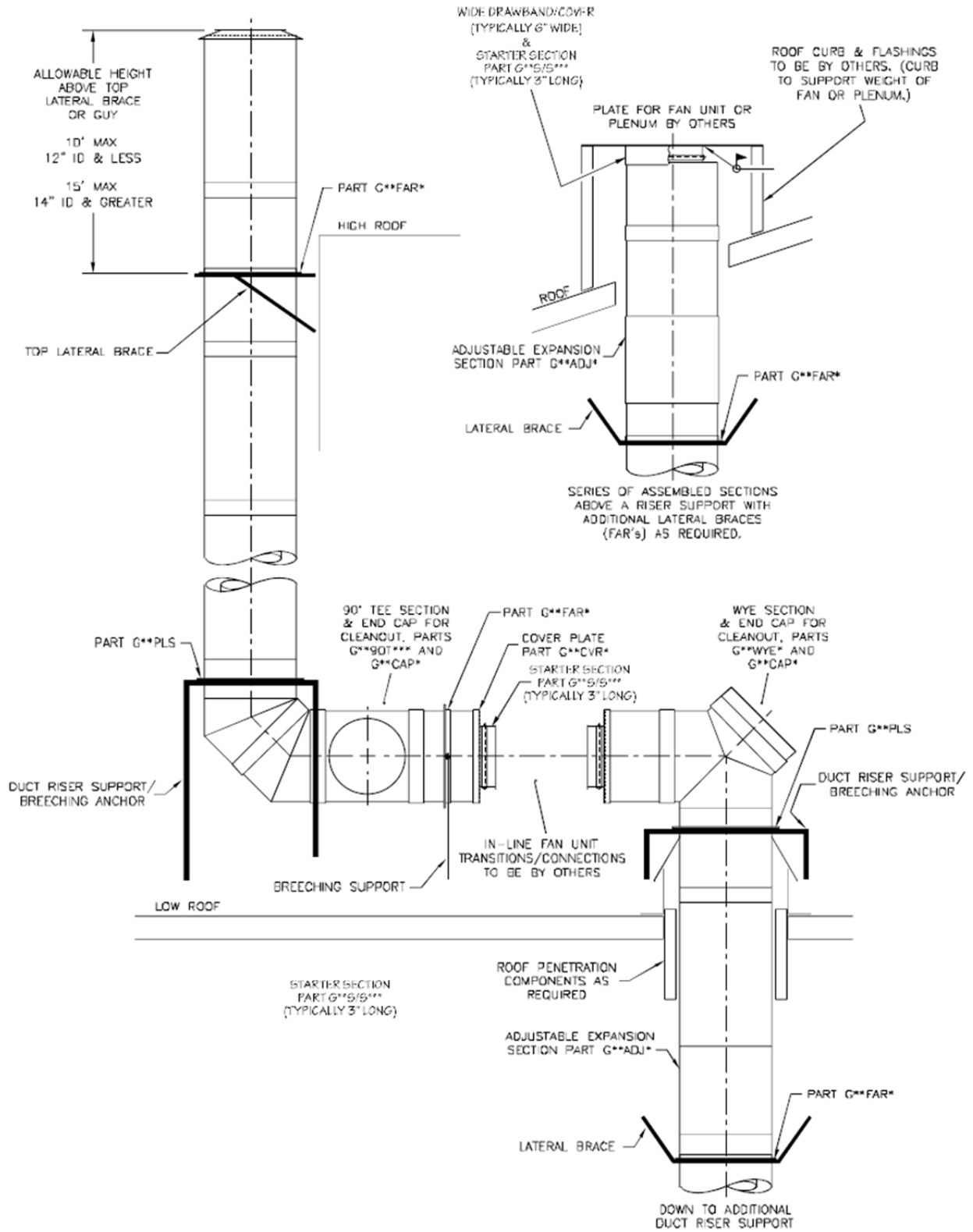

Figure 54
Typical Support Locations for Duct Risers

SQS ONLINE GZ DUCT PROGRAM MODULE

Spring Air Systems has made available to our sales representatives, engineers, and consultants an online Pre-Engineering duct drawing program. The user enters a line drawing of the ductwork connected to each hood and fan and the program provides scale drawings in plan and section, written specification and a quotation for the project.

The “Login” screen for SQS (Specification and Quoting System).



The login screen features a green gradient background. At the top left is the Spring Air logo, a stylized sunburst, followed by the text "Spring Air" and "Engineering Energy Savings" below it. The main title "SPECIFICATIONS AND QUOTING SYSTEM" is centered in large white letters. To the right of the title are two prompts: "Please enter your first name." and "Please enter your last name." Below these are three input fields: "First Name:", "Last Name:", and "Password:". A green "ENTER" button is positioned below the password field. At the bottom left, there is a small copyright notice: "Copyright © 2016 Spring Air Systems Inc."

Figure 55
The SQS Product Selection Screen

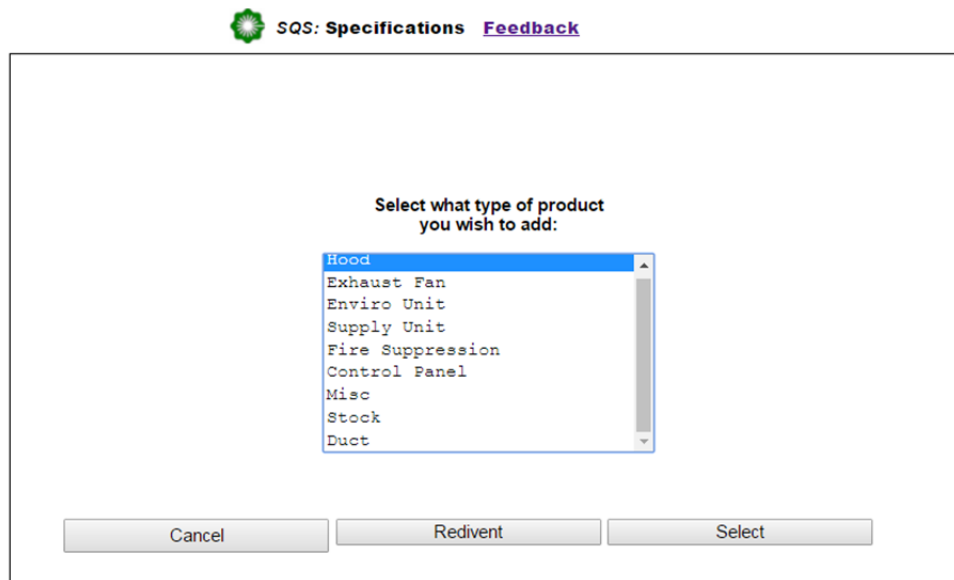

The product selection screen has a white background. At the top left is the Spring Air logo, followed by the text "SQS: Specifications" and a blue "Feedback" link. The main instruction is "Select what type of product you wish to add:". Below this is a list box containing the following items: Hood, Exhaust Fan, Enviro Unit, Supply Unit, Fire Suppression, Control Panel, Misc, Stock, and Duct. The "Hood" item is currently selected and highlighted in blue. At the bottom of the screen are three buttons: "Cancel", "Redivent", and "Select".

Figure 56
The SQS Product Selection Screen

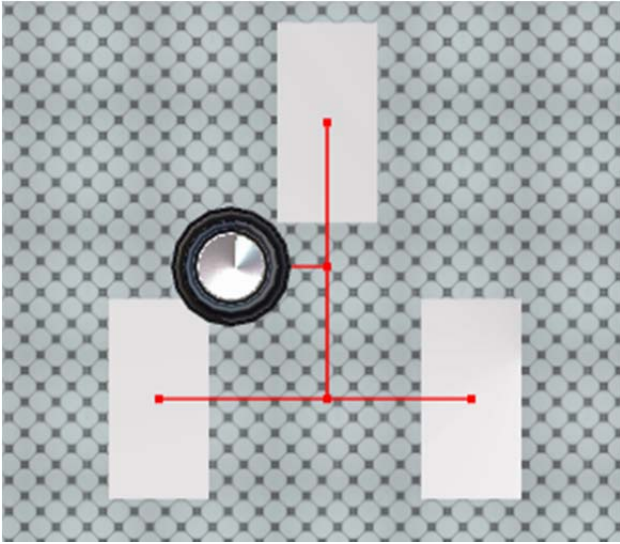

*Figure 57
Plan View of Ductwork Wire Frame
selection screen*

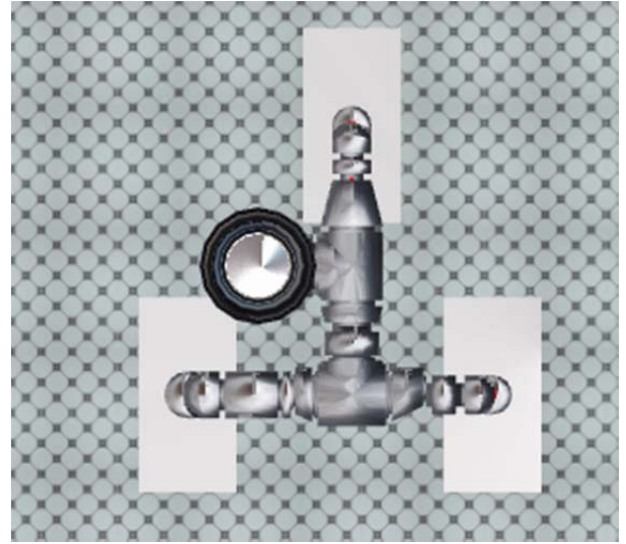

*Figure 58
Plan View of Ductwork Component
selection screen*

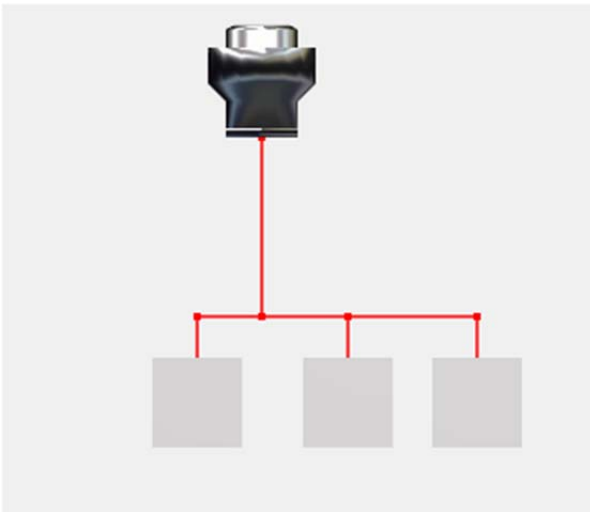

*Figure 59
Section View of Ductwork Wire
Frame selection screen*



*Figure 60 Section View of Ductwork
Component selection screen*

**Other Fine Products From
SPRING AIR SYSTEMS...**

- Water Wash Ventilators
 - ◆ Hot Water Wash
 - ◆ Cold Water Spray/Hot Water Wash
 - ◆ Water Wash Control Panels
- Dry Extractor Hoods
- **RevLow** Hoods
- **Dynaflow** Hoods
- Cartridge Hoods
- Filter Hoods
- Surface Fire Suppression
- Commercial Kitchen Exhaust Fans
- Kitchen Enviro Systems
 - ◆ KES - 100% Exhaust
 - ◆ KRS - 80% Recirculation in Canada
- Commercial Kitchen Supply Units
- Compensating Hoods
- Exhaust Fans
- **Zoneflow** Kitchen Exhaust Balancing Dampers
- Supply Fans
- Commercial Kitchen Control Panels
- Truflow Demand Ventilation Controls
- Capture-i & Captur-r
- Van-Packer Pre-Engineering Commercial Kitchen Ducts
- Utility Distributions Systems



Figure 61
 Screen Shot of 3D rotating screen with ductwork components

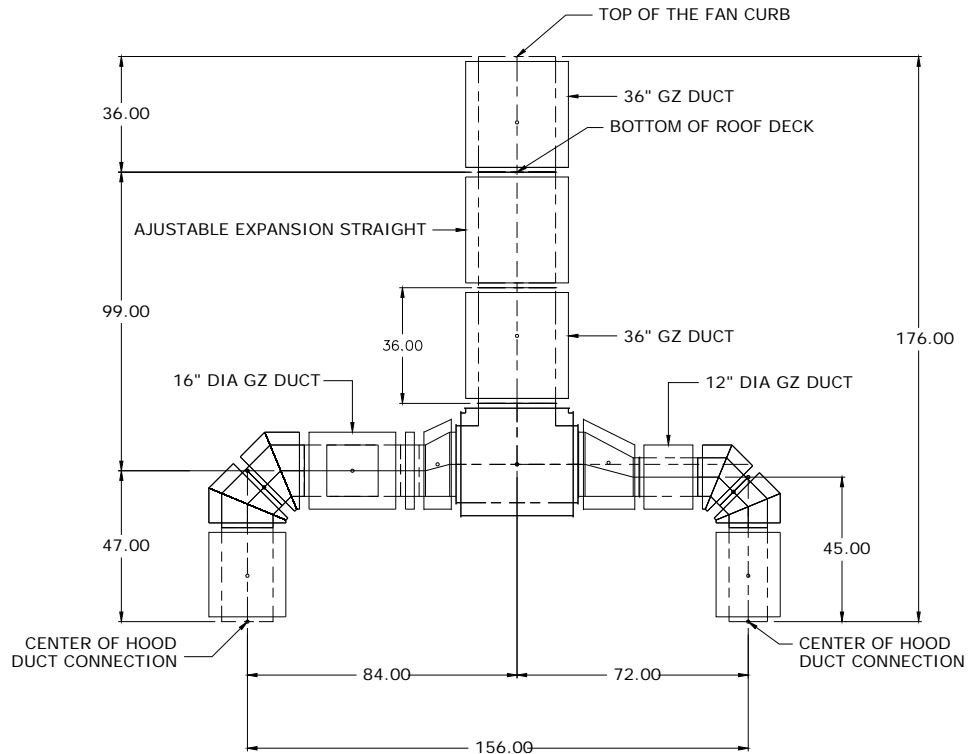

Figure 62
 CAD drawings of section view from X-Y plane from SQS program

Please contact you nearest Spring Air Systems Sales Representative online at www.springairsystems.com